

SENCOR®

Portable CD/MP3/USB Boombox with Analogue Radio

SPT 222

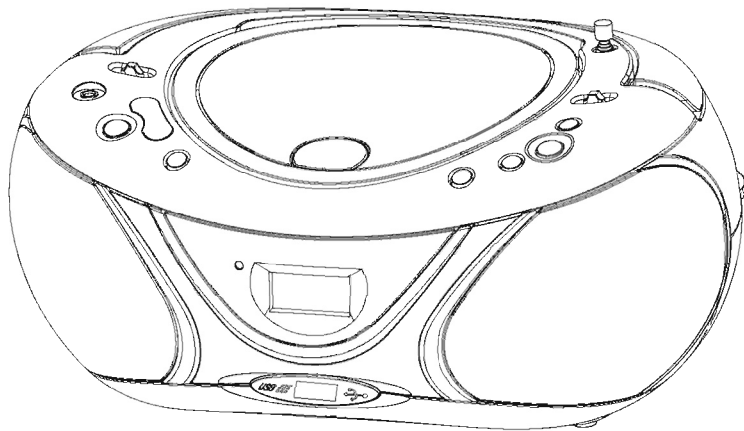

Instruction Manual



SAFETY PRECAUTIONS



Read this instruction and safety manual carefully before use. Keep this manual in a safe place for further reference.

WARNINGS

To reduce the risk of fire or electric shock, do not expose this product to rain or moisture.

EXPLANATION OF GRAPHIC SYMBOLS.

	HARZARD WARNING RISK OF ELECTRIC SHOCK DO NOT OPEN	
CAUTION: TO MINIMISE THE RISK OF ELECTRIC SHOCK, NEVER REMOVE THE COVER. THIS PRODUCT CONTAINS NO USER-SERVICEABLE PARTS. ONLY QUALIFIED REPAIR TECHNICIANS SHOULD WORK ON THIS EQUIPMENTS.		

	The lightning symbol inside an equilateral triangle warns the user of the presence inside the product of uninsulated hazardous electric voltages powerful enough to represent an electrocution risk.
	The exclamation mark symbol inside an equilateral triangle warns the user that important operating and servicing (troubleshooting) instructions are contained in the documentation accompanying the product.

HAZARD WARNING: TO REDUCE THE RISK OF FIRE OR ELECTRIC SHOCK, DO NOT EXPOSE THIS PRODUCT TO RAIN OR MOISTURE.
CLASS 1 LASER PRODUCT

CLASS 1 LASER PRODUCT
APPAREIL À LASER DE CLASSE 1
PRODUIT LASER DE CLASSE 1

CAUTIONS
INVISIBLE LASER RADIATION
WHEN OPEN AND INTERLOCKS
DEFEATED. AVOID EXPOSURE
TO BEAM.



This product contains a low-power emitter.

PRECAUTIONS FOR USE

To ensure safe use of this product, please follow the advice below:

Positioning

- Do not use the product in extremely hot, cold, dusty or damp condition.
- Place the product on a smooth, flat surface.

Do not obstruct the flow of air through the product. Place it on a well-ventilated position; do not cover with fabric or stand on a rug or carpet.

Power supply

- Before using this product, check that its rated voltage matches your mains power supply voltage.

Safety Instructions

- Never pull on the power cord when plugging in or unplugging the product: always use the plug pulling the cord could damage it and create a risk of electric shock.
- Unplug the product from the mains socket if you do not intend to use it for an extended period.

The On/Off button does not isolate the product from the power supply. To disconnect the product from the mains power supply, you must unplug the power cord.

- This product should only be used in a horizontal position.

Condensation

- Water droplets or condensation may form inside it if moved into a very warm, humid atmosphere.
- Condensation can cause the product to malfunction.
- Leave the set in a warm room for 1 to 2 hours to allow the condensation to evaporate.

In the event of a problem, unplug the power cord and contact a qualified repair technician.

Ventilation precautions

- Never obstruct the product's ventilation holes.

Warning concerning liquids

- Do not allow liquids to splash or spill onto the product, and never stand a liquid-filled container (vase, jar, etc.) on the top of it.

Warning concerning excessive sound levels

- Owing to this product's extremely low noise output and extended dynamic range, the user may be tempted to turn up the volume louder than necessary. The sound output may be excessively high, to the point of damaging the product's headphones or loudspeaker. Always keep the volume within reasonable limits.

Owner's record

For your convenience, record the model number and serial number for future reference.

Model : _____ Serial number : _____

SAFETY PRECAUTIONS

IMPORTANT INFORMATION

- This product is designed for use in a temperate environment. This apparatus must not be exposed to direct sunlight or extremely high temperatures and must not be installed near a radiator, kitchen range or any other device that produces heat.
- Do not place this apparatus in a location with high humidity (such as a bathroom or near a swimming pool). Do not use it in a location where it may be exposed to humidity, or dripping/spraying water.
- Do not place an open flame, such as burning candles, on the apparatus.
- If water enters the apparatus, immediately unplug the power cord and consult your retailer.
- Do not handle the power cable with wet hands. To avoid all risk of electrocution, NEVER touch the internal components of the apparatus. All servicing or repair must be performed by a qualified technician.
- When plugging in or unplugging the apparatus, do so while holding the plug and not the cable. The cable may be damaged if it is pulled to unplug the apparatus.
- Be careful not to drop the apparatus, allow liquids to spill inside or drop objects inside.
- Power is supplied to the apparatus even when it is in sleep mode. When the apparatus is not to be used for an extended period of time, it is recommended that it be disconnected as a safety precaution and to save electricity.
- If the power supply cable is damaged, cut or has an electrical contact fault, consult your retailer or nearest after-sales service facility.
- Do not fold, pull or twist the cable.
- Do not modify the power cable in any way.
- Do not insert metallic objects inside the apparatus.
- If the apparatus should catch fire, immediately disconnect the power supply cable.

INSTALLATION

- Keep a minimum gap of 15 cm around the unit for sufficient ventilation and air flow.
- Keep sufficient space around the unit to prevent any internal overheating. The ventilation should not be impeded by covering the ventilation openings with items such as newspapers, tablecloths, curtains and similar items. Never place the unit on a rug or in an insufficiently ventilated location.
- Place the unit on a flat and uniform surface.
- Do not use the unit in an excessively hot, cold, dusty or humid environment.
- Condensation may form inside the CD player if the apparatus is installed in a hot and humid location or if it is brought directly from a cold location to a warm place. In this case, avoid using the unit for 1 to 2 hours or progressively increase the ambient temperature to dry the unit before resuming operation.
- Do not place the unit in a location where it may be subject to vibrations.
- Do not place it in a location where it may be subjected to magnetic radiation from a magnet or speaker. As this apparatus contains magnets, do not insert cassettes: data may be erased.
- If this apparatus is placed next to a television, the image may experience interference. In this case, simply move the unit. If this is ineffective, unplug the unit when the television is on.
- Keep the CD compartment door closed so that the lens does not become dusty. Never touch the lens.

SAFETY MECHANISM

The apparatus features a safety locking mechanism which automatically deactivates the laser beam when the CD compartment is open.

FUNCTIONS AND CONTROLS

Front panel

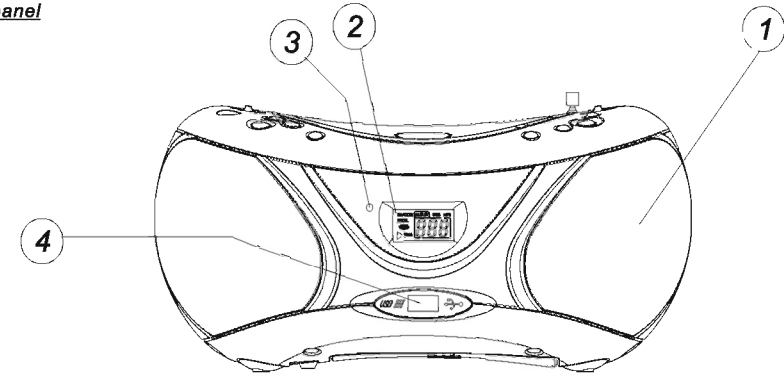

Upper panel

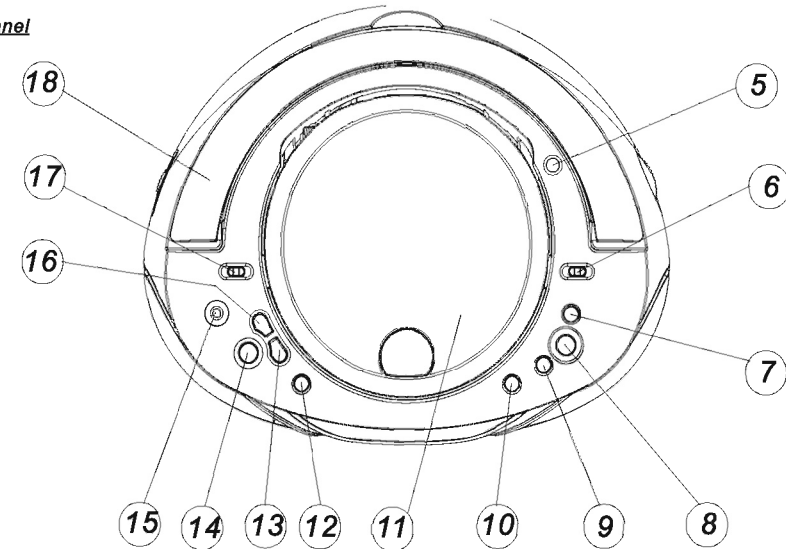

Rear panel

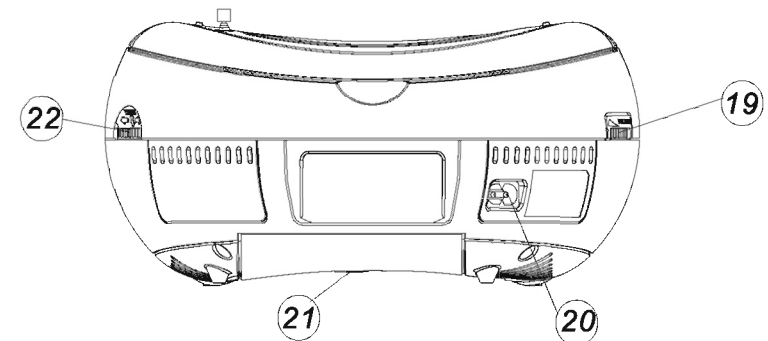

FUNCTIONS AND CONTROLS

FRONT PANEL

1. **SPEAKER**
2. **DISPLAY**
- display of CD functions.
3. **FM STEREO INDICATOR**
- display of FM stereo indications.
4. **USB JACK**
5. **TELESCOPIC ANTENNA**
- improvement of FM reception.
6. **BAND SELECTOR (AM•FM•FM ST.)**
- frequency band selection: AM, FM or FM ST.
7. **NEXT**
CD: next tracks.
8. **PLAY/PAUSE**
CD: start or pauses CD playback.
9. **BACK**
CD: return to the previous track.
10. **STOP**
CD: stops CD playback or delete a program.
11. **CD DOOR**
- CD compartment door open/close mark (OPEN/CLOSE).
12. **MODE**
Repeat 1/Repeat Album/Repeat All/Random.
13. **FOLDER DOWN**
14. **PROGRAM**
CD: programming and control of programmed track number.
15. **STEREO HEADPHONE JACK**
- connect for the 3.5mm stereo headphone.
16. **FOLDER UP**
17. **FUNCTION SELECTOR**
- source selection CD/MP3/USB or RADIO and power off.
18. **HANDLE**

REAR PANEL

19. **VOLUME CONTROL**
- sound level control.
20. **AC POWER SUPPLY**
- power supply cord connection.
21. **BATTERY COMPARTMENT COVER**
22. **TUNING KNOB**
- AM/FM/FM ST. stations selector.

POWER SUPPLY

If you would like, the electrical power supply can be used to save the batteries. Make sure that the unit is unplugged from the wall outlet before inserting the batteries.

USING THE DC POWER SUPPLY

Batteries (not included)

Open the battery compartment and insert 8 R14 batteries with respect to the "+" and "-" polarity indications in the compartment.

Important:

When replacing the batteries, make sure you dispose of the old batteries in accordance with applicable regulations. They should be disposed of in a location specifically designated for that purpose so they can be recycled safely and without posing any risk for the environment. Do not burn or bury them.

Incorrect use of the batteries may result in electrolyte leakage having a corrosive effect in the compartment.

- Do not mix different types of batteries: do not use alkaline batteries with saline batteries, for example. only use batteries of the type recommended by the manufacturer.
- Do not mix old and new batteries when inserting new ones.
- If the unit is not to be used for an extended period of time, remove the batteries from the unit.
- Batteries shall not be exposed to excessive heat such as sunshine, fire or the like.
- Warning: excessive sound pressure from earphones and headphones can cause hearing loss.

USING THE AC POWER SUPPLY

1. Make sure that the voltage indicated on the manufacturer's nameplate in the battery compartment corresponds to the voltage supplied by your electrical installation. If this is not the case, consult your dealer or service center.
2. Connect the electrical power cable the unit then plug it into the wall outlet. The wall outlet must be located near the product and be easily accessible.
3. To turn power to the apparatus off, unplug the power supply cable from the wall outlet.
4. To protect the unit during violent thunderstorms, unplug the power supply cable from the wall outlet.

GENERAL OPERATION

GENERAL OPERATION

1. Select the source by setting the **FUNCTION SELECTOR** to **CD/MP3/USB**, **OFF** or **RADIO**.
2. Set the desired volume level using the **VOLUME CONTROL**.
3. To turn off the unit, set the **FUNCTION SELECTOR** to **OFF**.

RADIO RECEPTION

1. Set the **FUNCTION SELECTOR** to **RADIO**.
2. Position the **BAND SELECTOR** on the desired band: **AM**, **FM** or **FM ST**.
3. Turn the **TUNING CONTROL** to search for the desired station.

NOTE: The FM stereo indicator comes on if the **BAND SELECTOR** is set on FM stereo and you have tuned the radio to an FM stereo station.

4. Adjust **VOLUME CONTROL** for the desired volume level.
5. When you have finished listening to the radio, position the **FUNCTION SELECTOR** to **OFF** to turn the unit off.

Hints for best reception:

FM: To listen to the FM radio, extend the telescopic antenna and orient it for optimum reception. Reduce the length of the antenna if the signal is too strong (if you are very near the transmitter, for example).

AM: As the unit is equipped with a built-in antenna, the telescopic antenna does not have to be used to listen to AM stations. Move the entire unit to orient the built-in antenna.

STEREO HEADPHONE JACK

Plug stereo headphones (not included), equipped with a 3.5mm mini-plug, into the **PHONES** jack (on top of the unit, left-hand side) for private listening, without disturbing those around you.

Reduce the **VOLUME** to a low level before putting on the headphones. You can then adjust the **VOLUME** progressively to a comfortable level.

CD/MP3/USB PLAYER OPERATION

CD/MP3 FILE PLAYBACK

The CD player supports audio discs, CD-R, CD-RW and MP3 files. Do not attempt to read CD-ROM, CDi, VCDs, DVDs or data CDs.

Note: Even if this portable radio-CD player is able to read CD-R and CD-RW discs, in addition to conventional compact discs, it is not possible to offer a 100% guarantee that all CD-R/RW discs can be read; playback depends on the quality and condition of the blank discs that you use, among other things. A playback failure does not necessarily indicate that the unit is malfunctioning.

1. Position the **FUNCTION SELECTOR** on **CD/MP3/USB** (the display unit briefly displays -- --).
 2. To open the CD player door, raise it by the corner marked **OPEN/CLOSE**.
 3. Insert a CD, CD-R, CD-RW or MP3 disc, printed surface facing upwards and gently press the CD player door to close it.
 4. Start playback by pressing **PLAY/PAUSE**.
- Press **PLAY/PAUSE** for 2 seconds to switch from **CD/MP3** to **USB** mode. Press **PLAY/PAUSE** again for 2 seconds to return to **CD/MP3** mode.
5. Press **PLAY/PAUSE** to interrupt or resume playback.
 6. To stop CD playback, press **STOP**.

NOTE: CD playback stops automatically when:

- the CD compartment is opened;
- the radio function is selected;
- the CD/MP3 is finished.

SELECTING A DIFFERENT TRACK

During playback, press **NEXT** or **BACK** on the unit or remote control unit to select a track.

- If you have selected a track number in Stop or Pause mode, press **PLAY/PAUSE** to resume playback.
- Briefly press **NEXT** to pass to the next track or press **NEXT** several times until the desired track number appears in the display.
- Briefly press **BACK** to return to the start of the current track.
- Press **BACK** several times to find a previous track.

SELECTING A DIFFERENT FOLDER

- Press **FOLDER UP** for 2 seconds. When the display unit flashes, press **NEXT** or **BACK** to select the desired folder.
 - To select the previous files, press **FOLDER DOWN**.
- (Comment: the **FOLDER UP/DOWN** function can only be activated if the disc contains at least 2 files)

SEARCHING FOR A PASSAGE ON A TRACK

1. Press and hold **BACK** or **NEXT** to read the track in fast forward mode at reduced volume.
2. When you have found the desired passage, release the **BACK** or **NEXT** button (normal playback resumes automatically).

MODE

Repeat: playback of the current track continuously.

Repeat all: playback of the entire CD continuously.

Album: playback of selected folder continuously.

Random: playback in random order continuously.

PROGRAMMING OF TRACK NUMBERS

Up to 20 tracks can be programmed in any order. If desired, a given track can be programmed more than once.

1. In **STOP** mode, press **BACK** or **NEXT** to select a track.
2. When the desired track number appears, press the **PROG** button once to record the track (the display unit displays "prog", briefly followed by the track number selected).
3. Repeat steps 1 and 2 to select and program the desired tracks.
4. To start playback of your programmed tracks, press **PLAY/PAUSE**.

PROGRAM CHECK

In **STOP** mode, press the **PROG**. button. (the display unit displays the track numbers in the order programmed).

DELETING A PROGRAM

Perform the following operations to delete the memory:

- Open the CD door;
- Select the **RADIO** source;
- Press **STOP** once.

USE WITH A USB KEY

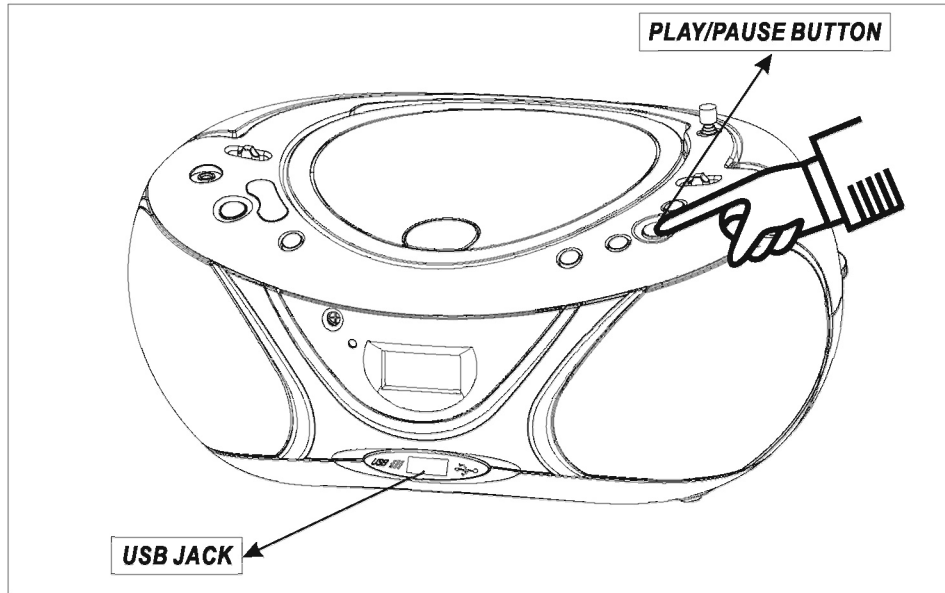

1. Slide the **FUNCTION SELECTOR** to **CD/MP3/USB**.
2. Insert your **USB key** into the **USB jack**.
3. Press and hold **PLAY/PAUSE** for 2 seconds to switch from **CD/MP3 mode** to **USB mode**.

The display unit shows:

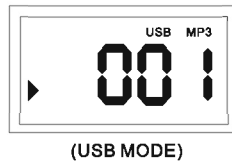

4. Start playback by pressing **PLAY/PAUSE**.
5. To stop playback, press **STOP**.

Press **PLAY/PAUSE** again for 2 seconds to return to **CD/MP3 mode**.
The display unit shows:

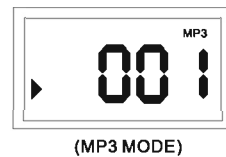
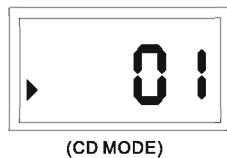

NOTE: Before removing your **USB key**, press **STOP** then press and hold **PLAY/PAUSE** for 2 seconds to return to **CD/MP3 mode**.

MAINTENANCE & SAFETY

OPERATING PRECAUTIONS AND GENERAL MAINTENANCE

- Place the unit on a hard and plane surface to ensure that it does not tip over.
- Do not expose the unit, batteries or the CDs to humidity, rain, sand or an excessive source of heat from a heater or direct sunlight.
- Do not open the apparatus. A gap of at least 15 cm must be kept between the ventilation openings and the surrounding surfaces in order to ensure sufficient ventilation and avoid all accumulation of heat.
- The unit's mechanism features self-lubricating bearings and thus do not require grease or lubrication.
- Use a soft and dry cloth to clean the unit. Never use cleaning agents containing alcohol, ammonia, benzene or abrasives, which may damage the cabinet.



CLEANING CDs

- Use a soft and clean cloth to wipe away fingerprints or dust from the surface of the disc.
- Wipe in a straight motion from the center to the edge. Very small dust particles and slight smudges have absolutely no effect on the sound quality.
- Never use chemical products such as sprays for conventional (vinyl) records, anti-static aerosols, benzene or thinners to clean your CDs.
- To reduce the risk of scratches, always store CDs in their case when not used.
- Do not expose CDs to direct sunlight, high humidity or excessively high temperatures for long periods of time.
- Never write or affix labels to the CD's surfaces.

CLEANING THE LENS

If the lens is dirty, the sound may skip and the CD may not be read correctly. Open the CD door and clean the lens as follows:

- Unplug the power cord.
- Dust or dry particles:
Blow on the lens several times using a camera lens brush, then wipe it gently with the brush to remove the dust. Then blow again on the lens.
- Fingerprints:
If you are unable to clean the lens with the camera lens brush, use a dry cotton swab to clean the surface, from the center to the outside.

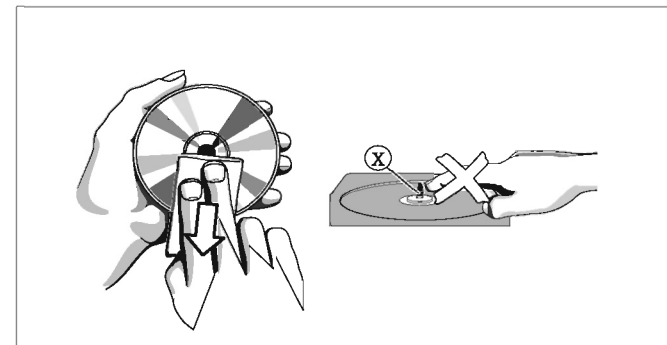

TROUBLESHOOTING

TROUBLESHOOTING

If a problem occurs, check the points below before taking the apparatus in for repair.

Do not open the apparatus to prevent all risk of electrocution.

If you are unable to solve a problem using the indications provided below, contact your dealer or after-sales service center.

WARNING: Under no circumstances should you attempt to repair the apparatus yourself; doing so will void the guarantee.

- Problem
- Solution

NO SOUND/ELECTRIC POWER

- The volume is not properly set.
- Adjust the volume.

- The electrical power cord is not plugged in correctly.
- Check the power cord connections.

- The batteries are dead/not inserted correctly.
- Check the installation and charge of the batteries.

THE DISPLAY UNIT DOES NOT FUNCTION CORRECTLY/THE BUTTONS DO NOT FUNCTION

- Electrostatic discharge.
- Turn the unit off and disconnect it. Plug it back in a few seconds later.

POOR CASSETTE SOUND QUALITY

- Dust and dirt on the heads, etc.
- Clean deck parts etc., See Maintenance.

- Use of incompatible cassette tapes (METAL or CHROME).
- Only use NORMAL (IEC I) for recording.

RECORDING DOES NOT WORK

- Cassette tab(s) may be broken.
- Apply a piece of adhesive tape over the missing tab space.

NO INFORMATION DISPLAYED ABOUT THE DISC

- No CD in the player.
- Insert a CD, CD-R or CD-RW in the player.

- The CD is scratched or very dirty.
- Replace/clean CD. See Maintenance.

- The CD-R is blank or the disc is not finalized.
- Use a finalized CD-R.

THE CD IS NOT READ

- The CD is scratched or very dirty.
- Replace/clean CD. See Maintenance.

THE CD SKIP TRACKS

- The CD is scratched or dirty.
- Replace/clean CD. See Maintenance.

- A program sequence was activated.
- Exit the programming mode(s).

SPECIFICATIONS

GENERAL

Power supply : AC 230V ~ 50Hz
: DC 12V = 8 x UM-2/R14 batteries (not included)

Dimensions of unit : 257(L) x 118(W) x 200(H) mm

Weight : 1.48 kg

Frequency range : AM 540 to 1600KHz
: FM 88 to 108MHz

AUDIO SECTION

Output power (RMS) : 2 x 1.2W

Speaker : 8 Ohms

Headphone : ø 3.5mm

(The technical characteristics are liable to change without notice)

Recycling

This symbol bears the selective sorting symbol for waste electrical and electronic equipment (WEEE). This means that this product must be handled pursuant to European Directive 2002/96/EC in order to be recycled or dismantled to minimize its impact on the environment.

For further information, please contact your local or regional authorities.

Electronic products not included in the selective sorting process are potentially dangerous for the environment and human health due to the presence of hazardous substances.

