

# MICROWAVE OVEN

## OWNER'S MANUAL

**PHILCO**



*Famous for Quality the World Over*

**PMD 205 R**  
**PMD 205 C**

**Dear customer,  
Thank you for buying a PHILCO brand product. So that your appliance serves you well, please read all the instructions in this user's manual.**

# CONTENTS

IMPORTANT SAFETY INSTRUCTIONS .....	2
EARTHING INSTRUCTIONS .....	7
INSTALLATION.....	7
SPECIFICATIONS .....	8
FEATURES DIAGRAM .....	10
OPERATION PROCEDURE.....	12
(ECO MODE) STAND-BY - HOW IT WORKS .....	13
CONTROLS .....	14
BEFORE YOU CALL FOR SERVICE.....	17
CARE OF YOUR MICROWAVE OVEN.....	18
CARING FOR YOUR MICROWAVE OVEN.....	19
QUESTIONS AND ANSWERS .....	19
COOKING INSTRUCTIONS .....	21
USE YOUR MICROWAVE OVEN SAFELY .....	22
MICROWAVING PRINCIPLES .....	23
CONVERSION CHARTS.....	25
COOKING TECHNIQUES.....	25
DEFROSTING GUIDE .....	27
COOKING & REHEATING CHART .....	28
VEGETABLE CHART .....	30

## IMPORTANT SAFETY INSTRUCTIONS

### READ CAREFULLY AND STORE FOR FUTURE USE

- This appliance may be used by children 8 years of age and older and by persons with physical or mental impairments or by inexperienced persons, if they are properly supervised or have been informed about how to use the product in a safe manner and understand the potential dangers.
- Children must not play with the appliance.
- Cleaning and maintenance performed by the user must not be performed by unsupervised children.
- In the event that the power cord is damaged, have it repaired at a professional service centre to prevent causing a dangerous situation. It is forbidden to use the appliance if it has a damaged power cord.



**Warning:**

If the door or the door gasket seal is damaged then the oven must not be used until repaired by an authorised service centre.



**Warning:**

It is dangerous for any untrained person to carry out any repairs or maintenance whatsoever that leads to the removal of any cover providing protection against microwave energy radiation.



**Warning:**

Liquids or other food must not be heated in closed containers as they could explode.

- This appliance is designed for domestic use and similar locations such as:
  - kitchens in stores; offices and other work environments;
  - in agriculture;
  - guests of hotels, motels and other accommodation environments;
  - in bed and breakfast establishments.
- To ensure sufficient air circulation, free space must be left around the microwave oven. Ensure free space of 20 cm above the top surface of the oven, 10 cm from behind and on the sides. Do not block any opening of the oven. Do not remove the feet of the oven.
- Use only containers that are suitable for use in microwave ovens.
- Do not use any of the following kitchen cookware, tableware or utensils in the microwave oven:
  - metal pans and crockery with metal handles or with metal decorations;
  - clamps on plastic bags;
  - dishes with melamine surface treatment;
  - standard thermometers, such as are used for measuring the temperature of meat, etc.
- When heating a meal on plastic or paper dishes, frequently check the oven to prevent them from catching on fire.
- The microwave oven is designed for heating food and beverages. Dehydrating food or drying clothes and heating up heating cushions, home footwear, washing sponges, damp textiles and similar items may lead to an injury hazard, ignition or fire.

- If smoke is being created, turn off the appliance or pull the plug out of the power socket and leave the door closed to prevent any potential fire from spreading.
- Microwave heating of drinks may cause a delayed boil, which must be considered when holding the container. Therefore, be careful when handling the container.
- The contents of baby bottles and baby food must be stirred through or shaken up and their temperature must be checked prior to consumption to prevent burns.
- Eggs in their shells and whole hard boiled eggs must not be heated in the microwave oven because they could explode even after the microwave heating process has finished.
- Regularly clean any food remains from the door and the window of the oven from both sides, the door gasket seal and neighbouring parts. For cleaning, we recommend the use of a weak kitchen detergent solution. Ensure that remains of the cleaning agent do not remain on the inside wall.
- Clean the oven regularly according to the above mentioned instructions and remove any food that remains inside it. Failure to keep the oven clean could lead to surface damage, which could adversely affect the lifetime of the appliance and could lead to a dangerous situation.
- The appliance must not be cleaned using a steam cleaner.
- This microwave oven is intended for use as a free-standing appliance. It is not designed to be installed into a cabinet.
- The microwave oven must not be placed into a cabinet.
- The microwave oven is intended to be placed on a countertop at a maximum height of 900 mm.

- Before connecting the appliance to a power socket, check that the voltage on its rating label matches the electrical voltage in the power socket.
- Connect the appliance only to a properly grounded socket.
- Do not use the microwave oven outdoors or subject it to the effects of the outdoor environment.
- Do not place the microwave oven on window sills, kitchen sink drainboards or unstable surfaces. Always place it on a stable, even and dry surface.
- Never use the microwave oven in the direct vicinity of a bath, shower or swimming pool.
- Do not use the microwave for industrial or laboratory purposes.
- Kitchen dishes may become hot as a result of the heat transferred from the heated food. Sometimes it is necessary to use kitchen gloves.
- Do not attempt to use the microwave oven with the door open. You could expose yourself to the harmful effect of microwaves. Do not run the microwave oven when it is empty.
- Be especially careful when handling heated beverages and foodstuffs as hot steam may be released from them.
- Do not fry food in the microwave oven. Hot oil may damage parts of the oven, dishes or may also cause skin burns.
- Before cooking, prick food that has a thick peel, such as potatoes, pumpkins, apples.
- When not using the oven, do not leave paper materials, kitchen dishes or food inside.

- Keep the inside of the oven clean. If the walls of the oven are splattered with food juices then wipe them away using a damp cloth. If the oven is heavily soiled, you can use a weak solution of a neutral kitchen detergent.
- Do not use the microwave oven if the power cord or power plug is damaged, if it is not working correctly, if it is damaged or if it has been dropped on the floor. Any repair of the microwave oven or replacement of a damaged power cord may only be carried out by an authorised service centre, as this will prevent a dangerous situation from occurring.

**PLEASE READ AND FOLLOW THE INSTRUCTIONS BELOW.  
SAVE THE INSTRUCTIONS IN CASE YOU NEED THEM AGAIN.**



## EARTHING INSTRUCTIONS

This appliance must be earthed. In the event of an electrical short circuit, earthing reduces the risk of electric shock by providing an escape wire for the electric current. This appliance is equipped with a cord having a earthing wire with an earthing plug. The plug must be plugged into an outlet that is properly installed and earthed.

**WARNING:** Improper use of the earthing plug can result in a risk of electric shock. Consult a qualified electrician or serviceman if the earthing instructions are not completely understood, or if doubt exists as to whether the appliance is properly earthed. If it is necessary to use an extension cord, use only a 3-wire extension cord that has a 3-blade earthing plug, and a 3-slot receptacle that will accept the plug on the appliance. The marked rating of the extension cord should be equal to or greater than the electrical rating of the appliance.

## INSTALLATION

### 1. Ventilation

Do not block air vents. If they are blocked during operation, the oven may overheat and eventually cause a failure. For proper ventilation, allow above 100mm of space between oven sides, rear and the minimum height of free space necessary above the top surface of the oven is 200mm.

### 2. Steady, flat location

This oven should be set on a steady, flat surface. This oven is designed for counter top use only. The microwave oven shall not be placed in a cabinet unless it has been tested in a cabinet.

### 3. Leave space behind and side

All air vents should be kept a clearance. If all vents are covered during operation, the oven may overheat and, eventually, oven failure.

### 4. Away from radio and TV sets

Poor television reception and radio interference may result if the oven is located close to a TV, Radio antenna, feeder and so on. Position the oven as far from them as possible.

### 5. Away from heating appliance and water taps

Keep the oven away from hot air, steam or Splash when choosing a place to position it, or the insulation might be adversely affected and breakdowns occur.

### 6. Power supply

- Check your local power source. This oven requires a current of approximately 6 amperes, 230V 50Hz.
- Power supply cord is about 0.8 meters long.
- The voltage used must be the same as specified on this oven. Using a higher voltage may result in a fire or other accident causing oven damage. Using low voltage will cause slow cooking. We are not responsible for damage resulting from use of this oven with a voltage of ampere fuse other than those specified.
- If the supply cord is damaged, it must be replaced by the manufacturer, its service agent or a similarly qualified persons in order to avoid a hazard.

**7. Examine the oven after unpacking for any damage such as:**

A misaligned door, Broken door, A dent in cavity. If any of the above is visible, DO NOT INSTALL, and notify dealer immediately.

**8. Do not operate the oven if it is colder than room temperature.**

(This may occur during delivery in cold weather.) Allow the oven to become room temperature before operating.

## SPECIFICATIONS

<b>POWER SUPPLY</b>	230V AC, 50Hz SINGLE PHASE WITH EARTHING
<b>MICROWAVE POWER CONSUMPTION</b>	1250 W
<b>MICROWAVE OUTPUT POWER</b>	800 W
<b>MICROWAVE FREQUENCY</b>	2450 MHz
<b>OUTSIDE DIMENSIONS (W X H X D)</b>	449 x 259 x 325 mm
<b>CAVITY DIMENSIONS (W X H X D)</b>	307 x 210 x 304 mm
<b>NET WEIGHT</b>	APPROX. 10 kg
<b>TIMER</b>	60 min.
<b>POWER LEVELS</b>	5 LEVELS

\* Specifications are subject to change without notice.

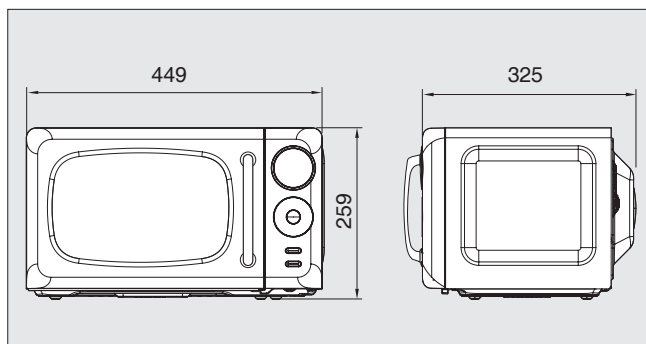

## IMPORTANT

The wires in this mains lead fitted to this appliance are coloured in accordance with the following code.

Green-and-yellow : Earth

Blue : Neutral

Brown : Live

As the colours of the wires in the mains lead of this appliance may not correspond with the coloured markings identifying the terminals in your plug, proceed as follows: the wire which is coloured green-and-yellow must be connected to the terminal in the plug which is marked with the letter 'E'; the earth symbol or coloured green-and-yellow. The wire which is coloured blue must be connected to the terminal which is marked with the letter 'N' or coloured black.

The wire which is coloured brown must be connected to the terminal which is marked with the letter 'L' or coloured red.

**WARNING:** This appliance must be earthed.

## FEATURES DIAGRAM

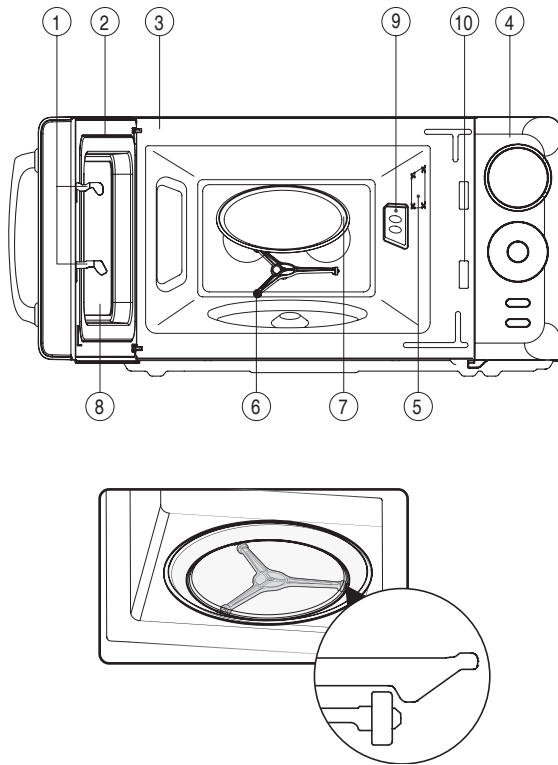

- ① **Door latch** - Latches on when the door is closed. If the door is opened while the oven is operating, the magnetron will automatically shut off.
- ② **Door seal** - The door seal prevents microwaves escaping from the oven cavity.
- ③ **Oven cavity**
- ④ **Control panel**
- ⑤ **Oven lamp** - Automatically turns on during oven operating.
- ⑥ **Roller guide** - This must always be used for cooking together with the glass cooking tray.
- ⑦ **Glass cooking tray** - Made of special heat resistant glass. The tray must always be in proper position before operating. Do not cook food directly on the tray and allows food to rotate for even cooking.
- ⑧ **Viewing screen** - Allows viewing of food.  
The screen is designed so that light can pass through, but not the microwave.
- ⑨ **Waveguide cover** - Protects the microwave outlet from splashes of cooking foods.
- ⑩ **Safety interlock system**

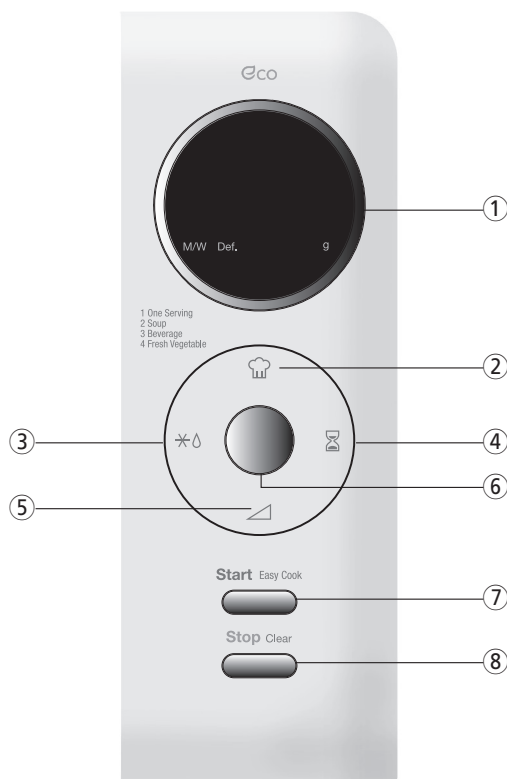

- ① **Display** - Cooking time, power level and indicators are displayed.
- ② **Auto cook** - Used to cook using a program or to reheat.
- ③ **Defrost** - Used to defrost foods by weight or time.
- ④ **Timer** - Used to set the timer.
- ⑤ **Power** - Used to set power level.
- ⑥ **Dial knob** - Used to set the time and weight.
- ⑦ **Start/Easy cook** - Used to start the oven operation and also increase the reheat time by 30 seconds.
- ⑧ **Stop/Clear** - Used to stop the oven operation or to erase all entries.

# OPERATION PROCEDURE

This section includes useful information about oven operation.

1. Plug power supply cord into 230V AC 50Hz power outlet.
  2. After placing the food in a suitable container, open the oven door and put it on the glass tray.  
The glass tray and roller guide must always be in place during cooking.
  3. Shut the door. Make sure that it is firmly closed.
  4. Set required programme and time, then press Start.
  5. Once cooking is complete take care removing container as it will be hot.
- 
- 1 The oven light turns on while the oven is working.
  - 2 The oven door can be opened at any time during operation. The oven will automatically shut off.
  - 3 Each time a button is pressed, a BEEP will sound to acknowledge the press.
  - 4 The oven automatically cooks on full power unless set to a lower power level.
  - 5 The display will show nothing when the oven is plugged in. When you open the door, the display is turned on and beep sounds.
  - 6 When the Stop/Clear button is pressed during the oven operation, the oven stops cooking and all information retained. To erase all information press the Stop/Clear button once more. If the oven door is opened during the oven operation, all information is retained.
  - 7 If the Start button is pressed and the oven does not operate, check the area between the door and door seal for obstructions and make sure the door is closed securely. The oven will not start cooking until the door is completely closed or the program has been reset.

Make sure the oven is properly installed and plugged into the electrical outlet.

## WATTAGE OUTPUT CHART

- The power-level is set by pressing the Power button. The chart shows the display, the power level and the percentage of power.

Press Power pads	Percentage of power	Output Power 800 W	
		Display	Wattage
once	100%	P-HI	800 W
twice	80%	P-80	640 W
3	60%	P-60	480 W
4	40%	P-40	320 W
5	20%	P-20	160 W

## (ECO MODE) STAND-BY - HOW IT WORKS

### What is Stand-by Power ...

**This oven has a special feature that can reduce stand-by power consumption by not unplugging or totally switching off.**

The oven will turn off automatically when not in use for 2 minutes after finishing working. Although the oven is always plugged in, the oven does not consume energy in power save mode at all. When a user will open the door once, the oven wake up out of power save mode and get ready to work.

Stand-by power refers to the electric power consumed by electronic and electrical appliances while they are switched off or in a stand-by mode.

### How to turn on the oven at first ...

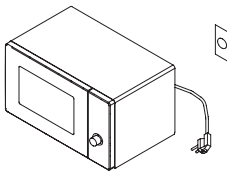

1. Now unplugged.

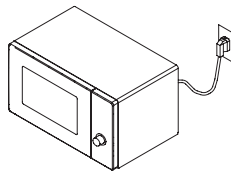

2. Connect its power cord to an outlet but its display will not turn on.

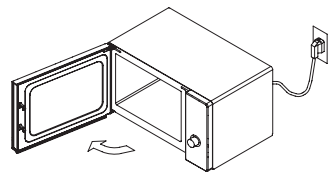

3. Open the door for using the oven and then its display will turn on.

### How to turn on the oven after working ...

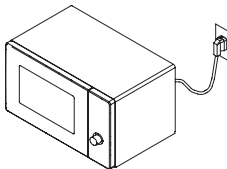

1. The oven will get turned off automatically when not in use for 2 minutes after finishing working.

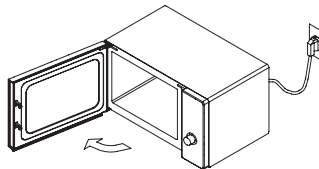

2. Open the door for using the oven and then its display will turn on.

## CONTROLS

### MICROWAVE COOK

---

This feature allows you to cook food with microwave energy.  
You can change the microwave power level from 100% to 20%.

---

1. Put food in the oven and close the door.
2. Press Power button to select the desired power level.  
The M/W indicator appears and the display will show what you selected.

Power

**NOTE: If step 2 is omitted, the oven will cook at full power.**

3. Turn the dial knob to adjust the cooking time.

**NOTE: You can enter the cooking time up to 60 minutes.**

Start

4. Press Start button.
- 

When you press Start button, the M/W indicator starts blinking to show the oven is cooking.  
The display counts down the time to show how much cooking time is left.  
When the cooking time ends, you will hear 3 beeps.

---

**NOTE: Using lower power levels increases the cooking time which is recommended for foods such as cheese, milk and slow cooking of meats.**

---

### EASY COOK

---

EASY COOK allows you to reheat for 30 seconds at full power by simply pressing the Easy cook button.  
By repeatedly pressing the Easy cook button, you can also extend reheating time to 5 minutes by 30 second increments.

---

1. Put food in the oven and close the door.
  2. Press Easy cook button.  
When you press Easy cook button, “:30” is displayed.  
The oven will start working automatically.  
When the cooking time ends, you will hear 3 beeps.
- 

Easy cook



## AUTO COOK

AUTO COOK allows you to cook your favorite foods

1. Put food in the oven and close the door.
2. Press Auto cook button to select the desired Auto cook menu.
3. Turn the DIAL KNOB to adjust the desired quantity.
4. Press Start button.  
When the cooking time ends, you will hear 3 beeps.

Auto cook

Start

Food	Press Autocook button	Display	Weigh	Directions
One serving	once	AC-1	350g	Put foods on the microwave plate and cover with vented plastic wrap.
			450g	
Soup	twice	AC-2	350g	Pour soup in microwave bowl or mug. Stir before serving.
			450g	
Beverage	three times	AC-3	1 CUP (200ml)	Pour beverage in microwave mug and place it on the turntable. Do not cover. Stir before serving.
			2 CUPS (200mlx2)	
			3 CUPS (200mlx3)	
Fresh vegetable	four times	AC-4	200g	Wash the vegetables and put them in a pot. Add no water if vegetables have just been washed. Cover tender vegetables with lid and stir after cooking.
			400g	

## TIMER

1. Open the door and close it again.
2. Press Timer button.
3. Turn the dial knob to set the timer.

Timer

**NOTE: You can enter the cooking time up to 60minutes.**

Start

4. Press Start button.  
When the timer ends, you will hear 3 beeps.

## WEIGHT DEFROST

---

WEIGHT DEFROST lets you easily defrost food by eliminating guesswork in determining defrosting time. The minimum weight for WEIGHT DEFROST is 100 gram and the maximum weight is 1,500 gram. Follow the steps below for easy defrosting.

---

1. Put food in the oven and close the door.
2. Press Defrost button.  
The DEF. indicator & "0" appear and the g indicator starts blinking.
3. Turn the dial knob to adjust the defrosting weight.
4. Press Start button.

Defrost

Start

When you press Start button, the g indicator disappears and the DEF. indicator starts blinking to show the oven is in the DEFROST mode. The display counts down the time to show you how much defrosting time is left in the DEFROST mode. The oven beeps during the defrosting cycle to signal that the food needs to be turned or rearranged. When the defrosting time ends, you will hear 3 beeps.

---

## TIME DEFROST

---

When TIME DEFROST is selected, the automatic cycle divides the defrosting time into periods of alternating defrost and stand times by cycling on and off.

---

1. Put food in the oven and close the door.
2. Press Defrost button.  
The DEF. indicator & "0" appear and the g indicator starts blinking.
3. Press Defrost button once more.  
The g indicator disappears and ":0" is displayed.
4. Turn the dial knob to adjust the defrosting time.  
The display will show what you selected.

**NOTE: You can enter the cooking time up to 60minutes.**

5. Press Start button.

Defrost

Start

When you press Start button, the DEF. indicator starts blinking to show the oven is the DEFROST mode. The display counts down the time to show you how much defrosting time is left in the DEFROST mode. The oven beeps during the defrosting cycle to signal that the food needs to be turned or rearranged. When the defrosting time ends, you will hear 3 beeps.

---

## TO STOP THE OVEN WHILE THE OVEN IS OPERATING

---

1. Press Stop/Clear button.
    - You can restart the oven by pressing Start button.
    - Press Stop/Clear button once more to erase all instructions.
    - You must enter in new instructions.
  2. Open the door.
    - You can restart the oven by closing the door and pressing Start button.
- 

**NOTE: Oven stops operating when door is opened.**

---

### WARNING

**If you see arcing, press STOP/CLEAR button and correct the problem.**

**Arcing is the microwave term for sparks in the oven. Arcing is caused by :**

- a) **Metal or foil touching the side of the oven.**
  - b) **Foil not molded to food (upturned edges act like antennas).**
  - c) **Metal such as twist-ties, poultry pins, or gold rimmed dishes in the microwave.**
  - d) **Recycled paper towels containing small metal pieces being used in the microwave.**
- 

## BEFORE YOU CALL FOR SERVICE

Refer to following checklist, you may prevent an unnecessary service call.

### \* **The oven doesn't work;**

1. Check that the power cord is securely plugged in.
2. Check that the door firmly closed.
3. Check that the cooking time is set.
4. Check for a blown circuit fuse or tripped main circuit breaker in your house.

### \* **Sparking in the cavity;**

1. Check that utensils are not and check that you are not using metal containers or dishes with metal trim.
2. Check that metal skewers do not touch the interior walls.

If there is still a problem, contact the customer service.

**DO NOT ATTEMPT TO SERVICE THE OVEN YOURSELF!**

## CARE OF YOUR MICROWAVE OVEN

**The oven should be cleaned regularly and any food deposits removed.**

**Failure to maintain the oven in a clean condition could lead to deterioration of the surface that could adversely affect the life of the appliance and possibly result in a hazardous situation.**

- 1** Turn the oven off before cleaning.
- 2** Keep the inside of the oven clean. When food spatters or spilled liquids adhere to oven walls, wipe with a damp cloth. Mild detergent may be used if the oven gets very dirty. The use of harsh detergent or abrasives is not recommended.
- 3** The outside oven surface should be cleaned with soap and water, rinsed and dried with a soft cloth. To prevent damage to the operating parts inside the oven, water should not be allowed to seep into the ventilation openings.
- 4** If the Control Panel becomes wet, clean with a soft, dry cloth. Do not use harsh detergents or abrasives on Control Panel.
- 5** If steam accumulates inside or around the outside of the oven door, wipe with a soft cloth. This may occur when the microwave oven is operated under high humidity conditions and in no way indicates malfunction of the unit.
- 6** It is occasionally necessary to remove the glass tray for cleaning. Wash the tray in warm sudsy water or in a dishwasher.
- 7** The roller guide and oven cavity floor should be cleaned regularly to avoid excessive noise. Simply wipe the bottom surface of the oven with mild detergent water or window cleaner and dry. The roller guide may be washed in mild sudsy water.

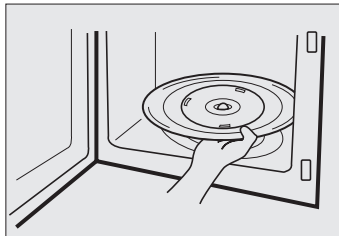

## CARING FOR YOUR MICROWAVE OVEN

The oven should be cleaned regularly and any food deposits removed. Failure to maintain the oven in a clean condition could lead to deterioration of the surface that could adversely affect the life of the appliance and possibly result in a hazardous situation.

1. Turn the oven off before cleaning.
2. Keep the inside of the oven clean. When food spatters or spilled liquids adhere to oven walls, wipe with a damp cloth. Mild detergent may be used if the oven gets very dirty. The use of harsh detergent or abrasives is not recommended.
3. The outside oven surface should be cleaned with soap and water, rinsed and dried with a soft cloth. To prevent damage to the operating parts inside the oven, water should not be allowed to seep into the ventilation openings.  
Ensure all food deposit are cleaned off, as they can carbonized if left.
4. If the Control Panel becomes wet, clean with a soft, dry cloth. Do not use harsh detergents or abrasives on Control Panel.
5. If steam accumulates inside or around the outside of the oven door, wipe with a soft cloth. This may occur when the microwave oven is operated under high humidity conditions and in no way indicates malfunction of the unit.
6. It is occasionally necessary to remove the glass tray for cleaning. Wash the tray in warm sudsy water or in a dishwasher.
7. The roller guide and oven cavity floor should be cleaned regularly to avoid excessive noise.  
Simply wipe the bottom surface of the oven with mild detergent water or window cleaner and dry.  
The roller guide may be washed in mild sudsy water.

## QUESTIONS AND ANSWERS

### **Can the oven be used with the glass tray or roller guide removed?**

No. Both the glass tray and roller guide must always be used in the oven before cooking.

### **Can I open the door when the oven is operating?**

The door can be opened anytime during the cooking operation. Then microwave energy will be instantly switched off and the time setting will maintain until the door is closed and START is pressed.

### **Why do I have moisture in my microwave oven after cooking?**

The moisture on the side of your microwave oven is normal. It is caused by steam from cooking food hitting the cool oven surface.

### **Does microwave energy pass through the viewing screen in the door?**

No. The metal screen bounces back the energy to the oven cavity. The holes are made to allow light to pass through. They do not let microwave energy pass through.

### **Why do eggs sometimes pop?**

When baking or poaching eggs, the yolk may pop due to steam build-up inside the yolk membrane. To prevent this, simply pierce the yolk with a toothpick before cooking. Never cook eggs without piercing their shells.

### **Why this standing time recommended after the cooking operation has been completed?**

Standing time is very important.

With microwave cooking, the heat is in the food, not in the oven. Many foods build up enough internal heat to allow the cooking process to continue, even after the food is removed from the oven. Standing time for joints of meat, large vegetables and cakes is to allow the inside to cook completely, without overcooking the outside.

### **What does “standing time” mean?**

Standing time” means that food should be removed from the oven and covered for additional time to allow it to finish cooking. This frees the oven for other cooking.

### **Why does my oven not always cook as fast as the microwave cooking guide says?**

Check your cooking guide again, to make sure you’ve followed directions exactly ; and to see what might cause variations in cooking time. Cooking guide times and heat settings are suggestions, to help prevent overcooking... the most common problem in getting used to a microwave oven. Variations in the size, shape and weights and dimensions could require longer cooking time. Use your own judgement along with the cooking guide suggestions to check whether the food has been properly cooked just as you would do with a conventional cooker.

### **Will the microwave oven be damaged if it operates while empty?**

Yes. Never run it empty. This will damage it. If the microwave is operated empty, the excess energy will be absorbed and focused at the weakest point of the cavity or door, potentially causing door melting/ arcing. The energy will not normally focus at this point with a normal amount of food material in the cavity. Low load items are items of food that contain little or no liquid.

### **Can I operate my microwave oven without the turntable or turn the turntable over to hold a large dish?**

No. If you remove or turn over the turntable, you will get poor cooking results. Dishes used in your oven must fit on the turntable.

### **Is it normal for the turntable to turn in either direction?**

Yes. The turntable rotates clockwise or counterclockwise, depending on the rotation of the motor when the cooking cycle begins.

### **Can I pop popcorn in my microwave oven? How do I get the best results?**

Yes. Pop packaged microwave popcorn following manufactures guidelines or use the preset POPCORN pad. Do not use regular paper bags. Use the “listening test” by stopping the oven as soon as the popping slows to a “pop” every 1 or 2 seconds. Do not repop unpopped kernels. Do not pop popcorn in glass cookware.

## COOKING INSTRUCTIONS

Only use utensils that are suitable for use in microwave ovens. To cook food in the microwave oven, the microwaves must be able to penetrate the food, without being reflected or absorbed by the dish used. Care must therefore be taken choosing the utensil. If the utensil is marked microwave-safe, you do not need to worry.

The following table lists various utensils and indicates whether and how they should be used in a microwave oven.

Utensil	Safe	Comments
<b>Aluminium foil</b>	▲	Can be used in small quantities to protect areas against overcooking. Arcing can occur if the foil is too close to the oven wall or if too much foil is used.
<b>Crisp plate</b>	●	Do not preheat for more than 8 minutes.
<b>China and earthenware</b>	●	Porcelain, pottery, glazed earthenware and bone china are usually suitable, unless decorated with a metal trim.
<b>Disposable polyester cardboard dishes</b>	●	Some frozen foods are packaged in these dishes.
<b>Fast-food packaging</b> <ul style="list-style-type: none"> <li>• Polystyrene cups containers</li> <li>• Paper bags or newspaper</li> <li>• Recycled paper or metal trims</li> </ul>	● X X	Can be used to warm food. Overheating may cause the polystyrene to melt. May catch fire.  May cause arcing.
<b>Glassware</b> <ul style="list-style-type: none"> <li>• Oven-to-table ware</li> <li>• Fine glassware</li>   <li>• Glass jars</li> </ul>	●  ● ●	Can be used, unless decorated with a metal trim. Can be used to warm foods or liquids. Delicate glass may break or crack if heated suddenly. Must remove the lid. Suitable for warming only.

Utensil	Safe	Comments
<b>Metal</b> <ul style="list-style-type: none"> <li>• Dishes</li> <li>• Freezer bag twist ties</li> </ul>	 X X	May cause arcing or fire.
<b>Paper</b> <ul style="list-style-type: none"> <li>• Plates, cups, napkins and Kitchen paper</li> <li>• Recycled paper</li> </ul>	●	For short cooking times and warming. Also to absorb excess moisture. May cause arcing.
<b>Plastic</b> <ul style="list-style-type: none"> <li>• Containers</li> <li>• Cling film</li> <li>• Freezer bags</li> </ul>	 ● ● ▲	Particularly if heat-resistant thermoplastic. Some other plastics may warp or discolour at high temperatures. Do not use Melamine plastic. Can be used to retain moisture. Should not touch the food. Take care when removing the film as hot steam will escape. Only if boilable or oven-proof. Should not be airtight. Prick with a fork, if necessary.
<b>Wax or grease-proof paper</b>	●	Can be used to retain moisture and prevent spattering.

● : Recommended use

▲ : Limited Use

X : Not Recommended

## USE YOUR MICROWAVE OVEN SAFELY

### General Use

Do not attempt to defeat or tamper with safety interlocks.

Do not place any object between the oven front frame and the door or allow residue to build up on sealing surfaces. Wipe with a mild detergent, rinse and dry. Never use abrasive powders or pads.

Do not subject the oven door to strain or weight such as a child hanging on an open door.

This could cause the oven to fall forward resulting in injury to you and damage to the oven.

Do not operate the oven if door seals or sealing surfaces are damaged; or if door is bent; or if hinges are loose or broken.

Do not operate the oven empty. This will damage the oven.

Do not attempt to dry clothes, newspapers or other materials in the oven. They may catch on fire.

Do not use recycled paper products as they may contain impurities which may cause sparks or fires.

Do not hit or strike the control panel with hard objects. This can damage the oven.



## Food

Always use the minimum recipe cooking time. It is better to undercook rather than overcook foods.

Undercooked foods can be returned to the oven for more cooking. If food is overcooked, nothing can be done.

Heat small quantities of food or foods with low moisture carefully. These can quickly dry out, burn or catch on fire.

Do not heat eggs in the shell. Pressure may build up and eggs can explode.

Potatoes, apples, egg yolks and sausages are examples of food with nonporous skins.

These must be pierced before cooking to prevent bursting.

Do not attempt to deep fat fry in your microwave oven.

Always allow a standing time of at least 20 seconds after the oven has been switched off to allow the temperature to even out, stir during heating, if necessary, and ALWAYS stir after heating. To prevent eruptive boiling and possible scalding, you should put a spoon or glass stick into the beverages and stir before, during and after heating.

Do not leave the oven unattended while popping corn.

Do not pop corn in a paper bag unless it is the commercially prepared Microwave Popcorn product.

The kernels can overheat and ignite a brown paper bag.

Do not put packaged Microwave Popcorn bags directly on the oven tray. Place the package on a microwave safe glass or ceramic plate to avoid overheating and cracking the oven tray.

Do not exceed the Microwave Popcorn manufacturers suggested popping time.

Longer popping does not yield more popcorn but it can result in scorch, burn or fire. Remember, the Popcorn bag and tray can be too hot to handle. Remove with caution and use pot holders.

Ensure all food deposits are cleaned off, as they can carbonize if left.

## ARCING

If you see arcing, press the **STOP/CLEAR** button and correct the problem.

Arcing is the microwave term for sparks in the oven.

Arcing is caused by:

- Metal or foil pressing the side of the oven.
- Foil not molded to food (upturned edges act like antennas).
- Metal, such as twist-ties, poultry pins, or gold rimmed dishes, in the microwave.
- Recycled paper towels containing small metal pieces being used in the microwave.

## MICROWAVING PRINCIPLES

Microwave energy has been used in this country to cook and reheat food since early experiments with RADAR in World War II. Microwaves are present in the atmosphere all the time, both naturally and manmade sources. Manmade sources include radar, radio, television, telecommunication links and car phones.

# HOW MICROWAVES COOK FOOD

Microwave oven is a Group 2 ISM equipment in which radiofrequency energy is intentionally generated and used in the form of electromagnetic radiation for the treatment of material. This oven is a Class B equipment suitable for use in domestic establishments and in establishments directly connected to a low voltage power supply network which supplies buildings used for domestic purposes.

In a microwave oven, electricity is converted into microwave by the MAGNETRON.

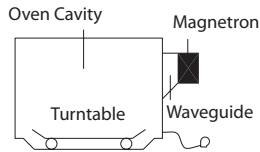

## ► REFLECTION

The microwaves bounce off the metal walls and the metal door screen.

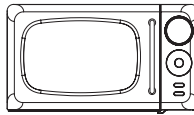

## ► TRANSMISSION

Then they pass through the cooking containers to be absorbed by the water molecules in the food, all foods contain water to a more or lesser extent.

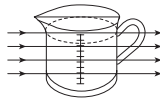

## ► ABSORPTION

The microwaves cause the water molecules to vibrate which causes FRICTION, i.e. HEAT. This heat then cooks the food. Microwaves are also attracted to fat and sugar particles, and foods high in these will cook more quickly.

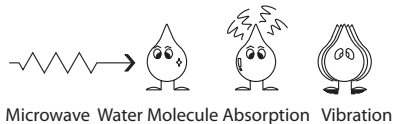

## CONVERSION CHARTS

WEIGHT MEASURES		VOLUME MEASURES		SPOON MEASURES	
15 g	1/2 oz.	30 ml	1 fl. oz.	1,25 ml	1/4 tsp
25 g	1 oz.	100 ml	3 fl. oz.	2,5 ml	1/2 tsp
50 g	2 oz.	150 ml	5 fl. oz. (1/4 pt.)	5 ml	1 tsp
100 g	4 oz.	300 ml	10 fl. oz. (1/2 pt.)	15 ml	1 tsp
175 g	6 oz.	600 ml	20 fl. oz. (1pt.)		
225 g	8 oz.				
450 g	1 g.				

FLUID MEASUREMENTS		
1 Cup	= 8 fl.oz.	= 240 ml
1 Pint	= 16 fl.oz. (UK 20 fl.oz.)	= 480 ml (UK = 560 ml)
1 Quart	= 32 fl.oz. (UK 40 fl.oz.)	= 960 ml (UK = 1 120 ml)
1 Gallon	= 128 fl.oz. (UK 160 fl.oz.)	= 3 840 ml (UK = 4 500 ml)

## COOKING TECHNIQUES

### STANDING TIME

Dense foods e.g. meat, jacket potatoes and cakes, require standing time (inside or outside of the oven) after cooking, to allow heat to finish conducting to cook the centre completely. Wrap meat joints and jacket potatoes in aluminium foil while standing. Meat joints need approx. 10-15 minutes, jacket potatoes 5 minutes. Other foods such as plated meal, vegetables, fish etc require 2-5 minutes standing. After defrosting food, standing time should also be allowed. If food is not cooked after standing time, return to the oven and cook for additional time.

### MOISTURE CONTENT

Many fresh foods e.g. vegetables and fruit, vary in their moisture content throughout the season, particularly jacket potatoes. For this reason cooking times may have to be adjusted. Dry ingredients e.g. rice, pasta, can dry out during storage so cooking times may differ.

### DENSITY

Porous airy foods heat more quickly than dense heavy foods.

### CLING FILM

Cling film helps keep the food moist and the trapped steam assists in speeding up cooking times. Pierce before cooking to allow excess steam to escape. Always take care when removing cling film from a dish as the buildup of steam will be very hot.

## **SHAPE**

Even shapes cook evenly. Food cooks better by microwave when in a round container rather than square.

## **SPACING**

Foods cook more quickly and evenly if spaced apart. NEVER pile foods on top of each other.

## **STARTING TEMPERATURE**

The colder the food, the longer it takes to heat up. Food from a fridge takes longer to reheat than food at room temperature.

## **LIQUIDS**

All liquids must be stirred before and during heating. Water especially must be stirred before and during heating, to avoid eruption. Do not heat liquids that have previously been boiled. DO NOT OVERHEAT.

## **TURNING & STIRRING**

Some foods require stirring during cooking. Meat and poultry should be turned after half the cooking time.

## **ARRANGING**

Individual foods e.g. chicken portions or chops, should be placed on a dish so that the thicker parts are towards the outside.

## **QUANTITY**

Small quantities cook faster than large quantities, also small meals will reheat more quickly than large portions.

## **PIERCING**

The skin or membrane on some foods will cause steam to build up during cooking. These foods must be pierced or a strip of skin should be peeled off before cooking to allow the steam to escape. Eggs, potatoes, apples, sausages etc, will all need to be pierced before cooking. DO NOT ATTEMPT TO BOIL EGGS IN THEIR SHELLS.

## **COVERING**

Cover foods with microwave cling film or a lid. Cover fish, vegetables, casseroles, soups. Do not cover cakes, sauces, jacket potatoes or pastry DEFROSTING GUIDE items.

## DEFROSTING GUIDE

Do not defrost covered meat. Covering might allow cooking to take place. Always remove outer wrap and tray. Use only containers that are microwave-safe.

Begin defrosting whole poultry breast-side-down. Begin defrosting roasts fat-side-down.

The shape of the package alters the defrosting time. Shallow rectangular shapes defrost more quickly than a deep block.

After 1/3 of the defrost time has elapsed, check the food. You may wish to turn over, break apart, rearrange or remove thawed portions of the food.

During defrost, the oven will prompt you to turn the over. At this point, open oven door and check the food. Follow the techniques listed below for optimum defrost results. Then, close oven door.

When defrosted, food should be cool, but softened in all areas. If still slightly icy, return to microwave oven very briefly, or let stand a few minutes. After defrosting, allow food to stand 5-60 minutes if there are any icy areas. Poultry and fish may be placed under running cool water until defrosted

- **Turn over:** Roast, ribs, whole poultry, turkey breasts, hot dogs, sausages, steaks, or chops.
- **Rearrange:** Break apart or separate steaks, chops, hamburger patties, ground meat, chicken or seafood pieces, chunks of meat such as stew beef.
- **Shield:** Use small strips of aluminum foil to protect thin areas or edges of unevenly shaped foods such as chicken wings. To prevent arching, do not allow foil to come within 1-inch of oven walls or door.
- **Remove:** To prevent cooking, thawed portions should be removed from the oven at this point. This may shorten defrost time for food weighing less than 3 lbs.(1350g).

# COOKING & REHEATING CHART

## Cooking chart

Item	Power Level	Cooking Time Per lb./450g	Special Instruction
<b>MEAT</b>			<ul style="list-style-type: none"> <li>- Chilled meat and poultry should be removed from the refrigerator at least 30 minutes before cooking.</li> <li>- Always let the meat and poultry stand, covered after cooking.</li> </ul>
Beef joint			
- Rare	640	8-10 min.	
- Medium	640	9-11 min.	
- Well done	640	11-13 min.	
Pork Joint	800	12-15 min.	
Bacon joint	800	8-10 min.	
<b>POULTRY</b>			
Whole chicken	800	7-9 min.	
Portions chicken	800	5-7 min.	
Breast (boned)	640	6-8 min.	
<b>FISH</b>			<ul style="list-style-type: none"> <li>- Brush a little oil or melted butter over the fish, or add 15~30ml (1-2 tbsp) lemon juice, wine, stock, milk or water.</li> <li>- Always let the fish stand, covered, after cooking</li> </ul>
Fish Fillets	800	4-6 min.	
Whole Mackerel, Cleaned and prepared	800	4-6 min.	
Whole Trout, Cleaned & Prepared	800	5-7 min.	
Salmon steaks	800	5-7 min.	
<b>NOTE:</b>			
The above times should be regarded only as a guide. Allow for difference in individual tastes and preferences. The times may vary due to the shape, cut, and composition of the food.			
Frozen meat, poultry and fish must be thoroughly thawed before cooking.			

## Reheating chart

- Baby food particularly needs to be checked carefully before serving to prevent burns.
- When heating pre-packaged ready-cooked foods, always follow the pack instructions carefully.
- If you freeze foods which were bought from the fresh or chilled counters, remember that they should be thoroughly thawed before following the heating instructions on the packet.  
It's worth putting a note on them so that other members of the household will remember too.
- Remember metal ties and transfer all food from foil containers before reheating.
- Chilled (refrigerated) food takes longer to reheat than food at room temperature (such as just-cooled food or food from the store cupboard).
- All foods should be reheated using full microwave power.

Item	Cooking time	Special Instructions
Baby food 128g jar	30 sec.	Empty into a small serving bowl. Stir well once or twice during heating. Before serving, check the temperature carefully.
Baby milk 100ml / 4fl.oz. 225ml / 8fl.oz.	20-30 sec. 40-50 sec.	Stir or shake well and pour into a sterilized bottle. Before serving, shake well and check the temperature carefully.
Sandwich roll or bun 1 roll	20-30 sec.	Wrap in paper towel and place on glass microwaveable rack. <b>* Note : Do not use recycled paper towels.</b>
Lasagna 1 serving (10 ½ oz./300g)	4-6 min.	Place lasagna on microwaveable plate. Cover with plastic wrap and vent.
Casserole 1 cup 4 cups	1 1/2-3 min. 5-7 min.	Cook covered in microwaveable casserole. Stir once halfway through cooking.
Mashed potatoes 1 cup 4 cups	2-3 min. 6-8 min.	Cook covered in microwaveable casserole. Stir once halfway through cooking.
Baked beans 1 cup	2-3 min.	Cook covered in microwaveable casserole. Stir once halfway through cooking.
Ravioli or pasta in sauce 1 cup 4 cups	3-4 min. 7-10 min.	Cook covered in microwaveable casserole. Stir once halfway through cooking.

## VEGETABLE CHART

Use a suitable glass pyrex bowl with lid. Add 30-45ml cold water (2-3 tbsp.) for every 250g unless another water quantity is recommended - see table.

Cook covered for the minimum time - see table.

Continue cooking to get the result you prefer. Stir once during and once after cooking. Add salt, herbs or butter after cooking. Cover during a standing time of 3 minutes.

Hint : cut the fresh vegetables into even sized pieces. The smaller they are cut, the quicker they will cook. All vegetables should be cooked using full microwave power.

### Cooking Guide for frozen vegetables

Vegetables	Weight	Time	Instructions
Spinach	0.3 lb./125g	2-3 min.	Add 15ml (1tbsp.) cold water.
Broccoli	½ lb./250g	3-4 min.	Add 30ml (2 tbsp.) cold water.
Peas	½ lb./250g	3-4 min.	Add 15ml (1 tbsp.) cold water.
Green beans	½ lb./250g	4-5 min.	Add 30ml (2 tbsp.) cold water.
Mixed vegetables (carrots/peas/corn)	½ lb./250g	3-4 min.	Add 15ml (1 tbsp.) cold water.
Mixed vegetables (Chinese style)	½ lb./250g	4-5 min.	Add 15ml (1 tbsp.) cold water.



## Cooking Guide for fresh vegetables

Vegetables	Weight	Time	Comments
Broccoli	½ lb./250g 1 lb./500g	2-3 min. 4-6 min.	Prepare even sized florets. Arrange the stems to the centre.
Brussels sprouts	½ lb./250g	3-4 min.	Add 60-75ml (5-6tbsp.) water.
Carrots	½ lb./250g	2-3 min.	Cut carrots into even sized slices.
Cauliflower	½ lb./250g 1 lb./500g	2-3 min. 4-6 min.	Prepare even sized florets. Cut big florets into halves. Arrange stems to the centre.
Courgettes	½ lb./250g	2-3 min.	Cut courgettes into slices. Add 30ml (2 tbsp.) water or a knob of butter. Cook until just tender.
Egg plants	½ lb./250g	2-3 min.	Cut egg plants into small slices and sprinkle with 1 tablespoon lemon juice.
Leeks	½ lb./250g	2-3 min.	Cut leeks into thick slices.
Mushrooms	0.3 lb./125g ½ lb./250g	1-2 min. 2-4 min.	Prepare small whole or sliced mushrooms. Do not add any water. Sprinkle with lemon juice. Spice with salt and pepper. Drain before serving.
Onions	½ lb./250g	2-3 min.	Cut onions into slices or halves. Add only 15ml (1 tbsp.) water.
Pepper	½ lb./250g	2-4 min.	Cut pepper into small slices.
Potatoes	½ lb./250g 1 lb./500g	3-5 min. 7-9 min.	Weigh the peeled potatoes and cut them into similar sized halves or quarters.
Turnip cabbage	½ lb./250g	3-5 min.	Cut turnip cabbage into small cubes.

## **CUSTOMER CARE AND SERVICE**

Always use original spare parts.

Model name and serial number can be found on the rating plate. Position of rating plate can be changed without notice.

The original spare parts for some specific components are available for a minimum of 7 or 10 years, based on the type of component, from the placing on the market of the last unit of the model.

When contacting our authorized service, have the model designation, serial number and defect description available.

To download documents, visit [www.philco.cz](http://www.philco.cz).

To report a defect and obtain additional service information, visit <https://philco.cz/podpora-a-servis>.

Subject to change without notice.

## INSTRUCTIONS AND INFORMATION REGARDING THE DISPOSAL OF USED PACKAGING MATERIALS

Dispose of packaging material at a public waste disposal site.

## DISPOSAL OF USED ELECTRICAL AND ELECTRONIC APPLIANCES



The meaning of the symbol on the product, its accessory or packaging indicates that this product shall not be treated as household waste. Please, dispose of this product at your applicable collection point for the recycling of electrical & electronic equipment waste. Alternatively in some states of the European Union or other European states you may return your products to your local retailer when buying an equivalent new product. The correct disposal of this product will help save valuable natural resources and help in preventing the potential negative impact on the environment and human health, which could be caused as a result of improper liquidation of waste. Please ask your local authorities or the nearest waste collection centre for further details. The improper disposal of this type of waste may fall subject to national regulations for fines.

### **For business entities in the European Union**

If you wish to dispose of an electrical or electronic device, request the necessary information from your seller or supplier.

### **Disposal in other countries outside the European Union**

If you wish to dispose of this product, request the necessary information about the correct disposal method from local government departments or from your seller.



This product meets all the basic EU regulation requirements that relate to it

Changes to the text, design and technical specifications may occur without prior notice and we reserve the right to make these changes.

Original of this user manual is in czech language.

Manufacturer/Importer:  
Fast ČR, a.s.  
Praha 10, Černokostecká 2111  
CZ-10000; CZECH REPUBLIC

**PHILCO**<sup>®</sup> 

**is a registered trademark used under license from  
Electrolux Home Products., Inc.**