

# REFRIGERATOR-FREEZER

## USER'S MANUAL

**PHILCO**



*Famous for Quality the World Over*

**PT 168 EMW**

**PT 168 EMX**

# CONTENTS

<b>PART 1: SAFETY INFORMATION.....</b>	<b>2</b>
1.1 General Safety Warnings.....	2
1.2 Installation warnings .....	12
1.3 During Usage.....	12
<b>PART 2: PROPER USE OF THE REFRIGERATOR.....</b>	<b>14</b>
2.1 Dimensions.....	15
<b>PART 3: USING THE APPLIANCE .....</b>	<b>16</b>
3.1 Information on Less Frost Technology.....	16
3.2 Thermostat Setting.....	16
3.3 Temperature Settings Warnings.....	17
3.4 Accessories .....	17
<b>PART 4: FOOD STORAGE.....</b>	<b>19</b>
4.1 Refrigerator Compartment.....	19
4.2 Freezer Compartment .....	20
<b>PART 5: CLEANING AND MAINTENANCE .....</b>	<b>24</b>
5.1 Defrosting .....	24
<b>PART 6: SHIPMENT AND REPOSITIONING .....</b>	<b>26</b>
6.1 Transportation and Changing Positioning.....	26
6.2 Repositioning the Door.....	26
<b>PART 7: BEFORE CALLING AFTER-SALES SERVICE .....</b>	<b>27</b>
<b>PART 8: TIPS FOR SAVING ENERGY .....</b>	<b>28</b>
<b>PART 9: PRODUCT INFORMATION SHEET .....</b>	<b>29</b>

 This appliance has been tested in accordance with the directives in force in the European Union. This appliance conforms to the relevant safety provisions for electrical appliances in force in the European Union.

## PART 1: SAFETY INFORMATION

### 1.1 General Safety Warnings



FOR YOUR SAFETY AND CORRECT USAGE, BEFORE INSTALLING AND FIRST USING THE APPLIANCE, READ THIS USER MANUAL CAREFULLY, INCLUDING ITS HINTS AND WARNINGS. TO AVOID UNNECESSARY MISTAKES AND ACCIDENTS, IT IS IMPORTANT TO MAKE SURE THAT ALL PEOPLE USING THE APPLIANCE ARE THOROUGHLY FAMILIAR WITH ITS OPERATION AND SAFETY FEATURES. SAVE THESE INSTRUCTIONS AND BE SURE THAT THEY REMAIN WITH THE APPLIANCE IF IT IS MOVED OR SOLD, SO THAT ANYONE USING IT THROUGHOUT ITS LIFE, WILL BE PROPERLY INFORMED ON ITS USAGE AND SAFETY NOTICES. FOR THE SAFETY OF LIFE AND PROPERTY, KEEP THE PRECAUTIONS OF THESE USER'S INSTRUCTIONS AS THE MANUFACTURER IS NOT RESPONSIBLE FOR DAMAGES CAUSED BY OMISSION.

- THIS APPLIANCE CAN BE USED BY CHILDREN AGED FROM 8 YEARS AND ABOVE AND PERSONS WITH REDUCED PHYSICAL, SENSORY OR MENTAL CAPABILITIES OR LACK OF EXPERIENCE AND KNOWLEDGE IF THEY HAVE BEEN GIVEN SUPERVISION OR INSTRUCTION CONCERNING USE OF THE APPLIANCE IN A SAFE WAY AND UNDERSTAND THE HAZARDS INVOLVED.
- CHILDREN AGED FROM 3 TO 8 YEARS ARE ALLOWED TO LOAD AND UNLOAD REFRIGERATING APPLIANCES.
- CHILDREN SHALL NOT PLAY WITH THE APPLIANCE.
- CLEANING AND USER MAINTENANCE CANNOT BE PERFORMED BY CHILDREN WITHOUT SUPERVISION.

- IF THE SUPPLY CABLE GETS DAMAGED, HAVE IT REPLACED BY A SPECIALIZED SERVICE CENTER IN ORDER TO AVOID DANGEROUS SITUATIONS. IT IS PROHIBITED TO USE THE APPLIANCE WHEN THE SUPPLY CABLE IS DAMAGED.

- **WARNING:** THE VENTILATION OPENINGS IN THE APPLIANCE HOUSING OR IN ITS CONSTRUCTION MUST BE KEPT FREE.

- **WARNING:** DO NOT USE MECHANICAL DEVICES OR OTHER MEANS TO ACCELERATE THE DEFROSTING PROCESS, OTHER THAN THOSE RECOMMENDED BY THE MANUFACTURER.

- **WARNING:** DO NOT DAMAGE THE REFRIGERANT CIRCUIT.

- **WARNING:** DO NOT USE ELECTRICAL APPLIANCES INSIDE THE FOOD STORAGE COMPARTMENTS OF THE APPLIANCE, UNLESS THEY ARE OF THE TYPE RECOMMENDED BY THE MANUFACTURER.

- **WARNING:** DO NOT STORE EXPLOSIVE SUBSTANCES SUCH AS AEROSOL CANS WITH A FLAMMABLE PROPELLANT IN THIS APPLIANCE.

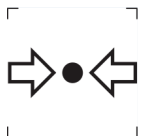

ISO 7000-1701 MARK (2004-01)  
LABELS MEDIA UNDER PRESSURE.

THIS APPLIANCE IS INTENDED TO BE USED IN HOUSEHOLDS AND SIMILAR PREMISES, SUCH AS:

- KITCHENETTES IN SHOPS, OFFICES AND OTHER WORKPLACES;
- APPLIANCES USED BY GUESTS IN HOTELS, MOTELS, AND OTHER ACCOMMODATION FACILITIES;
- APPLIANCES USED IN BED-AND-BREAKFAST FACILITIES;
- APPLIANCES USED IN CATERING AND OTHER SIMILAR NON-VENDING ENVIRONMENTS.

● **CAUTION:** THE APPLIANCE MUST BE FASTENED IN ACCORDANCE WITH THE MANUAL TO PREVENT DANGER CAUSED BY ITS INSTABILITY.



**WARNING :**  
RISK OF FIRE / FLAMMABLE MATERIALS

CONTAINS COOLING GAS ISOBUTANE

# R600a

## REFRIGERANT

THE REFRIGERANT ISOBUTENE (R600a) IS CONTAINED WITHIN THE REFRIGERANT CIRCUIT OF THE APPLIANCE, A NATURAL GAS WITH A HIGH LEVEL OF ENVIRONMENTAL COMPATIBILITY, WHICH IS NEVERTHELESS FLAMMABLE. DURING TRANSPORTATION AND INSTALLATION OF THE APPLIANCE, ENSURE THAT NONE OF THE COMPONENTS OF THE REFRIGERANT CIRCUIT BECOMES DAMAGED. THE REFRIGERANT (R600a) IS FLAMMABLE.

● **WARNING** — REFRIGERATORS CONTAIN REFRIGERANT AND GASES IN THE INSULATION. REFRIGERANT AND GASES MUST BE DISPOSED OF PROFESSIONALLY AS THEY MAY CAUSE EYE INJURIES OR IGNITION. ENSURE THAT TUBING OF THE REFRIGERANT CIRCUIT IS NOT DAMAGE PRIOR TO PROPER DISPOSAL.



THE SYMBOL  IS A WARNING AND INDICATES THE REFRIGERANT AND INSULATION BLOWING GAS ARE FLAMMABLE.

## **WARNING : RISK OF FIRE / FLAMMABLE MATERIALS**

IF THE REFRIGERANT CIRCUIT SHOULD BE DAMAGED:

- AVOID OPENING FLAMES AND SOURCES OF IGNITION.
- THOROUGHLY VENTILATE THE ROOM IN WHICH THE APPLIANCE IS SITUATED.

IT IS DANGEROUS TO ALTER THE SPECIFICATIONS OR MODIFY THIS PRODUCT IN ANY WAY.

ANY DAMAGE TO THE CORD MAY CAUSE A SHORT CIRCUIT, FIRE, AND/OR ELECTRIC SHOCK.

● **CAUTION:** WHEN PLACING THE APPLIANCE IT MUST BE ENSURED THAT THE SUPPLY CORD DOES NOT GET CAUGHT OR DAMAGED.

● **CAUTION:** DO NOT PLACE PORTABLE MULTIPLE SOCKET-OUTLETS OR PORTABLE EXTENSION CABLES TO THE REAR SIDE OF THE APPLIANCE.

CONTACT THE SERVICE CENTRE FOR REPAIRS OR LIGHTING REPLACEMENT.

● OPENING THE DOOR FOR LONGED PERIODS OF TIME CAN CAUSE A SIGNIFICANT INCREASE IN TEMPERATURE WITHIN THE APPLIANCE.

● SURFACES THAT MAY COME INTO CONTACT WITH FOOD AND ACCESSIBLE DRAINAGE SYSTEMS SHOULD BE CLEANED REGULARLY.

● IN THE REFRIGERATOR, RAW MEAT AND FISH MUST BE STORED IN APPROPRIATE PACKAGING SO THAT THEY DON'T COME INTO CONTACT WITH OTHER FOOD OR DRIP ONTO IT.

● TWO STAR FREEZER COMPARTMENTS ARE SUITABLE FOR STORING PRE-FROZEN FOODS, FOR STORING OR PRODUCTION OF ICE CREAM AND FOR PRODUCTION OF ICE CUBES.

● ONE, TWO AND THREE STAR COMPARTMENTS ARE NOT SUITABLE FOR FREEZING FRESH FOOD.

IF THE COOLING APPLIANCE IS LEFT EMPTY FOR A LONGER PERIOD OF TIME, IT SHOULD BE SWITCHED OFF, DEFROSTED, CLEANED AND DRIED AND THE DOOR SHOULD BE LEFT OPEN TO PREVENT MOULD FROM FORMING INSIDE THE APPLIANCE.



## **ELECTRICAL SAFETY**

1. THE POWER CORD MUST NOT BE LENGTHENED.
2. MAKE SURE THAT THE POWER PLUG IS NOT CRUSHED OR DAMAGED.  
A CRUSHED OR DAMAGED POWER PLUG MAY OVERHEAT AND CAUSE A FIRE.
3. MAKE SURE THAT YOU CAN ACCESS THE MAIN PLUG OF THE APPLIANCE.
4. DO NOT PULL THE MAIN CABLE.
5. IF THE POWER PLUG SOCKET IS LOOSE, DO NOT INSERT THE POWER PLUG. THERE IS A RISK OF ELECTRIC SHOCK OR FIRE.
6. YOU MUST NOT OPERATE THE APPLIANCE WITHOUT THE INTERIOR LIGHTING LAMP COVER.
7. THE FRIDGE IS ONLY APPLIED WITH POWER SUPPLY OF SINGLE PHASE ALTERNATING CURRENT OF 220~240V/50HZ. IF FLUCTUATION OF VOLTAGE IN THE DISTRICT OF USER IS SO LARGE THAT THE VOLTAGE EXCEEDS THE ABOVE SCOPE, FOR SAFETY SAKE, BE SURE TO APPLY A.C. AUTOMATIC VOLTAGE REGULATOR OF MORE THAN 350W TO THE FRIDGE.



THE FRIDGE MUST EMPLOY A SPECIAL POWER SOCKET INSTEAD OF COMMON ONE WITH OTHER ELECTRIC APPLIANCES. ITS PLUG MUST MATCH THE SOCKET WITH GROUND WIRE.

## **DAILY USE**

- DO NOT STORE FLAMMABLE GAS OR LIQUIDS IN THE APPLIANCE, THERE IS A RISK OF AN EXPLOSION.
- DO NOT OPERATE ANY ELECTRICAL APPLIANCES IN THE APPLIANCE (E.G. ELECTRIC ICE CREAM MAKERS, MIXERS ETC.).
- WHEN UNPLUGGING ALWAYS PULL THE PLUG FROM THE MAINS SOCKET, DO NOT PULL ON THE CABLE.
- DO NOT PLACE HOT ITEMS NEAR THE PLASTIC COMPONENTS OF THIS APPLIANCE.
- DO NOT PLACE FOOD PRODUCTS DIRECTLY AGAINST THE AIR OUTLET ON THE REAR WALL.
- STORE PRE-PACKED FROZEN FOOD IN ACCORDANCE WITH THE FROZEN FOOD MANUFACTURE'S INSTRUCTIONS.
- THE APPLIANCES MANUFACTURES STORAGE RECOMMENDATIONS SHOULD BE STRICTLY ADHERED TO. REFER TO RELEVANT INSTRUCTIONS FOR STORAGE.
- DO NOT PLACE CARBONATED OR FIZZY DRINKS IN THE FREEZER COMPARTMENT AS IT CREATES PRESSURE ON THE CONTAINER, WHICH MAY CAUSE IT TO EXPLODE, RESULTING IN DAMAGE TO THE APPLIANCE.
- FROZEN FOOD CAN CAUSE FROST BURNS IF CONSUMED STRAIGHT FROM THE FREEZER COMPARTMENT.
- DO NOT PLACE THE APPLIANCE IN DIRECT SUNLIGHT.
- KEEP BURNING CANDLES, LAMPS AND OTHER ITEMS WITH NAKED FLAMES AWAY FROM THE APPLIANCE SO THAT DO NOT SET THE APPLIANCE ON FIRE.

- THE APPLIANCE IS INTENDED FOR KEEPING FOOD STUFF AND/OR BEVERAGES IN NORMAL HOUSEHOLD AS EXPLAINED IN THIS INSTRUCTION BOOKLET. YOU SHOULD TAKE CARE WHEN MOVE IT AS THE APPLIANCE IS HEAVY.
- DO NOT REMOVE OR TOUCH ITEMS FROM THE FREEZER COMPARTMENT IF YOUR HANDS ARE DAMP/WET, AS THIS COULD CAUSE SKIN ABRASIONS OR FROST/FREEZER BURNS.
- NEVER USE THE BASE, DRAWERS, DOORS ETC. TO STAND ON OR AS SUPPORTS.
- FROZEN FOOD MUST NOT BE REFROZEN ONCE IT HAS BEEN THAWED OUT.
- DO NOT CONSUME ICE POPSICLES OR ICE CUBES STRAIGHT FROM THE FREEZER AS THIS CAN CAUSE FREEZER BURN TO THE MOUTH AND LIPS.
- TO AVOID ITEMS FALLING AND CAUSING INJURY OR DAMAGE TO THE APPLIANCE, DO NOT OVERLOAD THE DOOR RACKS OR PUT TOO MUCH FOOD IN THE CRISPER DRAWERS.

## **INSTALLATION IMPORTANT!**

- FOR ELECTRICAL CONNECTION CAREFULLY, FOLLOW THE INSTRUCTIONS GIVEN IN THIS MANUAL. UNPACK THE APPLIANCE AND CHECK IF THERE ARE DAMAGES ON IT.
- DO NOT CONNECT THE APPLIANCE IF IT IS DAMAGED. REPORT POSSIBLE DAMAGES IMMEDIATELY TO THE PLACE YOU BOUGHT IT. IN THIS CASE RETAIN PACKING.
- IT IS ADVISABLE TO WAIT AT LEAST FOUR HOURS BEFORE CONNECTING THE APPLIANCE TO ALLOW THE OIL TO FLOW BACK IN THE COMPRESSOR.
- ADEQUATE AIR CIRCULATION SHOULD BE AROUND THE APPLIANCE, LACKING THIS LEADS TO OVERHEATING. TO ACHIEVE SUFFICIENT VENTILATION, FOLLOW THE INSTRUCTIONS RELEVANT TO INSTALLATION.
- WHEREVER POSSIBLE THE BACK OF THE PRODUCT SHOULD NOT BE TOO CLOSE TO A WALL TO AVOID TOUCHING OR CATCHING WARM PARTS (COMPRESSOR, CONDENSER) TO PREVENT THE RISK OF A FIRE, FOLLOW THE INSTRUCTIONS RELEVANT TO INSTALLATION.
- THE APPLIANCE MUST NOT BE LOCATE CLOSE TO RADIATORS OR COOKERS.
- MAKE SURE THAT THE MAINS PLUG IS ACCESSIBLE AFTER THE INSTALLATION OF THE APPLIANCE.
- PLACE ALL PACKAGING MATERIALS OUT OF THE REACH OF CHILDREN, THERE IS A RISK OF SUFFOCATION.
- THE INTERIOR OF YOUR REFRIGERATOR / FREEZER MAY SMELL BEFORE FIRST USE. THIS IS NORMAL. THE ODOR DISAPPEARS AS SOON AS THE APPLIANCE STARTS TO COOL / FREEZE.

- BEFORE CONNECTING THE REFRIGERATOR I FREEZER, MAKE SURE THAT THE MAINS VOLTAGE CORRESPONDS TO THE REQUIREMENTS FOR CONNECTING THE REFRIGERATOR / FREEZER. IF IN DOUBT, CONSULT A QUALIFIED ELECTRICIAN.
- THE APPLIANCE MUST BE CONNECTED TO A SOCKET WITH THE APPROPRIATE VOLTAGE AND A CORRECTLY INSTALLED FUSE SOCKET.
- THE REFRIGERATOR I FREEZER MUST NOT BE PLACED OUTDOORS OR EXPOSED TO RAIN.
- THE REFRIGERATOR I FREEZER MUST BE LOCATED AT LEAST 50CM FROM HEATERS, ELECTRIC OVENS, GAS OVENS, ETC.
- IF THE REFRIGERATOR WITH FREEZER IS LOCATED NEXT TO THE FREEZER, THERE MUST BE A MIN. 2CM SPACING.
- DO NOT PLACE HEAVY OBJECTS ON THE REFRIGERATOR / FREEZER, DO NOT COVER IT.
- ABOVE THE FRIDGE / FREEZER THERE MUST BE A MIN. 100 - 150 MM FREE SPACE.
- THIS APPLIANCE IS MADE FOR DOMESTIC USE AND IS ONLY SUITABLE FOR COOLING / FREEZING FOOD. NOT SUITABLE FOR COMMERCIAL USE AND / OR STORAGE OF SUBSTANCES OTHER THAN FOOD. THE MANUFACTURER IS NOT LIABLE FOR ANY LOSSES CAUSED BY IMPROPER USE OF THE APPLIANCE.

## 1.2 Installation warnings

Before using your fridge freezer for the first time, please pay attention to the following points:

- The operating voltage for your fridge freezer is 220-240 V at 50Hz.
- The plug must be accessible after installation.
- Your fridge freezer may have an odour when it is operated for the first time. This is normal and the odour will fade when your fridge freezer starts to cool.
- Before connecting your fridge freezer, ensure that the information on the data plate (voltage and connected load) matches that of the mains electricity supply. If in doubt, consult a qualified electrician.
- Insert the plug into a socket with an efficient ground connection. If the socket has no ground contact or the plug does not match, we recommend you consult a qualified electrician for assistance.
- The appliance must be connected with a properly installed fused socket.  
The power supply (AC) and voltage at the operating point must match with the details on the name plate of the appliance (the name plate is located on the inside left of the appliance).
- We do not accept responsibility for any damages that occur due to ungrounded usage.
- Place your fridge freezer where it will not be exposed to direct sunlight.
- Your fridge freezer must never be used outdoors or exposed to rain.
- Your appliance must be at least 50 cm away from stoves, gas ovens and heater cores, and at least 5 cm away from electrical ovens.
- If your fridge freezer is placed next to a deep freezer, there must be at least 2 cm between them to prevent humidity forming on the outer surface.
- Do not cover the body or top of fridge freezer with lace. This will affect the performance of your fridge freezer.
- Clearance of at least 150 mm is required at the top of your appliance. Do not place anything on top of your appliance.
- Do not place heavy items on the appliance.
- Clean the appliance thoroughly before use (see Cleaning and Maintenance).
- Before using your fridge freezer, wipe all parts with a solution of warm water and a teaspoon of sodium bicarbonate. Then, rinse with clean water and dry. Return all parts to the fridge freezer after cleaning.
- Use the adjustable front legs to make sure your appliance is level and stable.  
You can adjust the legs by turning them in either direction. This must be done before placing food in the appliance.
- Install the plastic distance guide(s) on the condenser (black vanes at the rear of the appliance) by turning it 90° (as shown in the figure) to prevent the condenser from touching the wall.
- The distance between the appliance and back wall must be a maximum of 75 mm.

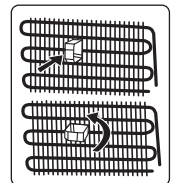

## 1.3 During Usage

- Do not connect your fridge freezer to the mains electricity supply using an extension lead.
- Do not use damaged, torn or old plugs.
- Do not pull, bend or damage the cord.
- Do not use plug adapter.
- This appliance is designed for use by adults. Do not allow children to play with the appliance or hang off the door.
- Never touch the power cord/plug with wet hands. This may cause a short circuit or electric shock.
- Do not place glass bottles or cans in the ice-making compartment as they will burst when the contents freeze.

- Do not place explosive or flammable material in your fridge. Place drinks with high alcohol content vertically in the fridge compartment and make sure their tops are tightly closed.
- When removing ice from the ice-making compartment, do not touch it. Ice may cause frost burns and/or cuts.
- Do not touch frozen goods with wet hands. Do not eat ice-cream or ice cubes immediately after they are removed from the ice-making compartment.
- Do not re-freeze thawed frozen food. This may cause health issues such as food poisoning.

### Old and Out-of-order Fridges

- If your old fridge or freezer has a lock, break or remove the lock before discarding it, because children may get trapped inside it and may cause an accident.
- Old fridges and freezers contain isolation material and refrigerant with CFC. Therefore, take care not to harm environment when you are discarding your old fridges.

### CE Declaration of conformity

We declare that our products meet the applicable European Directives, Decisions and Regulations and the requirements listed in the standards referenced.

### Disposal of your old appliance

The symbol on the product or on its packaging indicates that this product may not be treated as household waste. Instead it shall be handed over to the applicable collection point for the recycling of electrical and electronic equipment. By ensuring this product is disposed of correctly, you will help prevent potential negative consequences for the environment and human health, which could otherwise be caused by inappropriate waste handling of this product. For more detailed information about recycling of this product, please contact your local city office, your household waste disposal service or the shop where you purchased the product.

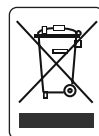

### Packaging and the Environment

Packaging materials protect your machine from damage that may occur during transportation. The packaging materials are environmentally friendly as they are recyclable. The use of recycled material reduces raw material consumption and therefore decreases waste production.



### Notes:

- Please read the instruction manual carefully before installing and using your appliance. We are not responsible for the damage occurred due to misuse.
- Follow all instructions on your appliance and instruction manual, and keep this manual in a safe place to resolve the problems that may occur in the future.
- This appliance is produced to be used in homes and it can only be used in domestic environments and for the specified purposes. It is not suitable for commercial or common use. Such use will cause the guarantee of the appliance to be cancelled and our company will not be responsible for any losses incurred.
- This appliance is produced to be used in houses and it is only suitable for cooling / storing foods. It is not suitable for commercial or common use and/or for storing substances except for food. Our company is not responsible for any losses incurred by inappropriate usage of the appliance.

## PART 2: PROPER USE OF THE REFRIGERATOR

This appliance is not intended to be used as a built-in appliance.

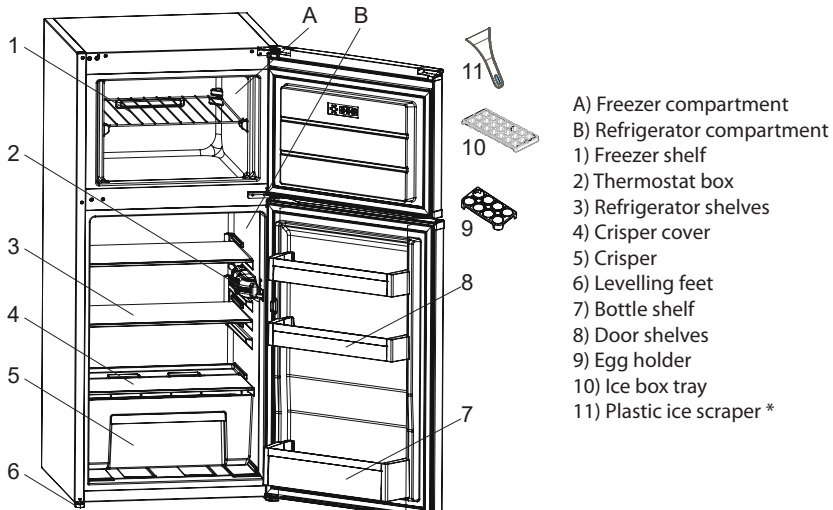

\* In some models



This presentation is only for information about the parts of the appliance. Parts may vary according to the appliance model.

### General notes:

#### Fresh Food Compartment (Fridge):

Most efficient use of energy is ensured in the configuration with the drawers in the bottom part of the appliance, and shelves evenly distributed, position of door bins does not affect energy consumption.

#### Freezer Compartment (Freezer): Most

Efficient use of energy is ensured in the configuration with the drawers and bins are on stock position.

## 2.1 Dimensions

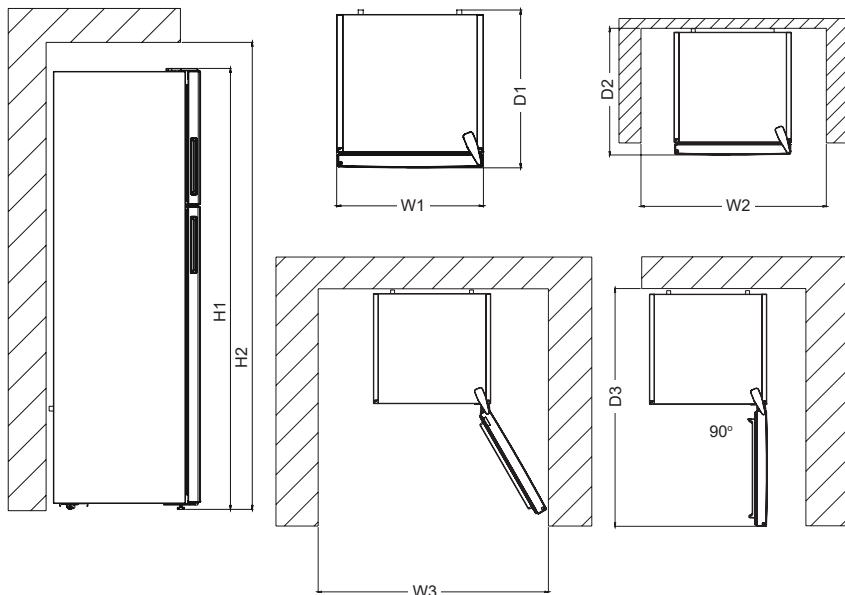

Overall dimensions <sup>1</sup>		
H1	mm	1230
W1	mm	540
D1	mm	570
<sup>1</sup> the height, width and depth of the appliance without the handle.		
Space required in use <sup>2</sup>		
H2	mm	1380
W2	mm	640
D2	mm	667,8
<sup>2</sup> the height, width and depth of the appliance including the handle, plus the space necessary for free circulation of the cooling air.		
Overall space required in use <sup>3</sup>		
W3	mm	658,5
D3	mm	1106,5
<sup>3</sup> the height, width and depth of the appliance including the handle, plus the space necessary for free circulation of the cooling air, plus the space necessary to allow door opening to the minimum angle permitting removal of all internal equipment.		



## PART 3: USING THE APPLIANCE

### 3.1 Information on Less Frost Technology

Thanks to the wrap around evaporator, Less Frost technology offers more efficient cooling, less manual defrost requirement, and more flexible storage room.

### 3.2 Thermostat Setting

The thermostat automatically regulates the temperature inside the cooler and freezer compartments. Refrigerator temperatures can be obtained by rotating the knob to higher numbers; 1 to 3, 1 to 5 or SF (Maximum numbers on the thermostat depends on your product.)



**Important note:**

Do not try to rotate the knob beyond position 1, it will stop your appliance from working.

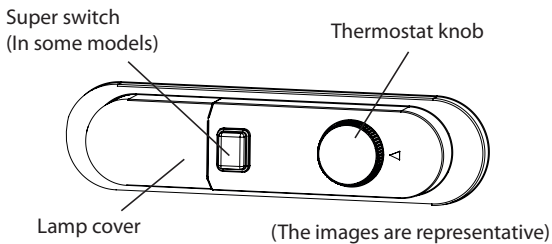

**Thermostat settings:**

**1 – 2 :** For short-term storage of food

**3 – 4 :** For long-term storage of food

**5 :** Maximum cooling position. The appliance will work longer. If required, change the temperature setting.

If device has SF position:

- Turn the knob to SF to freeze fresh food quickly. In this position, the freezer compartment will operate at lower temperatures. After your food freezes, turn the thermostat knob to its normal use position. If you do not change the SF position, your appliance work will automatically return to its last used thermostat position according to the time indicated in the note. Return the thermostat switch to the SF position and return it to normal use according to the time indicated in the note. If the thermostat switch is in the SF position when your appliance is first started, your appliance work will automatically return to the operation in the thermostat -3 position according to the time indicated in the note.

**Super freezing:**

This switch shall be used as super freeze switch. For maximum freezing capacity, please turn on this switch before 24 hours placing fresh food. After placing fresh food in the freezer, 24 hours ON position is generally sufficient. In order to save energy, please turn off this switch after 24 hours from placing fresh food.

**Winter Switch:**

If ambient temperature is below 16 °C, this switch shall be used as winter switch and it keeps your fridge above 0 °C while freezer is below -18 °C in low ambients.

## 3.3 Temperature Settings Warnings

- Your appliance is designed to operate in the ambient temperature ranges stated in the standards, according to the climate class stated in the information label. It is not recommended that your fridge is operated in the environments which are outside of the stated temperature ranges. This will reduce the cooling efficiency of the appliance.
- Temperature adjustments should be made according to the frequency of door openings, the quantity of food kept inside the appliance and the ambient temperature in the location of your appliance.
- When the appliance is first switched on, allow it to run for 24 hours in order to reach operating temperature. During this time, do not open the door and do not keep a large quantity of food inside.
- A 5 minute delay function is applied to prevent damage to the compressor of your appliance when connecting or disconnecting to mains, or when an energy breakdown occurs. Your appliance will begin to operate normally after 5 minutes.

**Climate class and meaning:**

**T (tropical):** This refrigerating appliance is intended to be used at ambient temperatures ranging from 16 °C to 43 °C.

**ST (subtropical):** This refrigerating appliance is intended to be used at ambient temperatures ranging from 16 °C to 38 °C.

**N (temperate):** This refrigerating appliance is intended to be used at ambient temperatures ranging from 16 °C to 32 °C.

**SN (extended temperate):** This refrigerating appliance is intended to be used at ambient temperatures ranging from 10 °C to 32 °C.

## 3.4 Accessories

**Visual and text descriptions in the accessories section may vary according to the model of your appliance.**

### 3.4.1 Ice Tray (In some models)

- Fill the ice tray with water and place in the freezer compartment.
- After the water has completely frozen, you can twist the tray as shown below to remove the ice cubes.

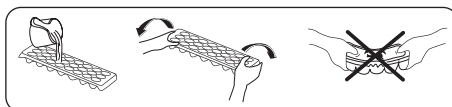

### 3.4.2 The Plastic Scraper (In some models)

After some time, frost will build up in certain areas of the freezer. The frost accumulated in the freezer should be removed regularly.

Use the plastic scraper provided, if necessary. Do not use sharp metal objects for this operation. They could puncture the refrigerator circuit and cause irreparable damage to the unit.

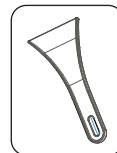

### 3.4.3 The Bottle Holder (In some models)

Use the bottle holder to prevent bottles from slipping or falling over.

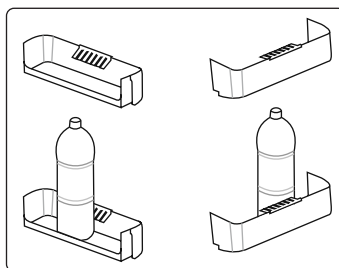
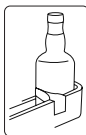

**Visual and text descriptions in the accessories section may vary according to the model of your appliance.**

### 4.1 Refrigerator Compartment

- To reduce humidity and avoid the consequent formation of frost, always store liquids in sealed containers in the refrigerator. Frost tends to concentrate in the coldest parts of the evaporating liquid and, in time, your appliance will require more frequent defrosting.
- Cooked dishes must remain covered when they are kept in the fridge. Do not place warm foods in fridge. Place them when they are cool, otherwise the temperature/humidity inside the fridge will increase, reducing the fridge's efficiency.
- Make sure no items are in direct contact with the rear wall of the appliance as frost will develop and packaging will stick to it. Do not open the refrigerator door frequently.
- We recommend that meat and clean fish are loosely wrapped and stored on the glass shelf just above the vegetable bin where the air is cooler, as this provides the best storage conditions.
- Store loose fruit and vegetable items in the crisper containers.
- Storing fruit and vegetables separately helps prevent ethylene-sensitive vegetables (green leaves, broccoli, carrot, etc.) being affected by ethylene-releasing fruits (banana, peach, apricot, fig etc.).
- Do not put wet vegetables into the refrigerator.
- Storage time for all food products depends on the initial quality of the food and an uninterrupted refrigeration cycle before refrigerator storage.
- Water leaking from meat may contaminate other products in the refrigerator. You should package meat products and clean any leakages on the shelves.
- Do not put food in front of the air flow passage.
- Consume packaged foods before the recommended expiry date.

Do not allow food to come into contact with the temperature sensor, which is located in the refrigerator compartment, in order to keep the refrigerator compartment at optimum temperature.

- For normal working conditions, it will be sufficient to adjust the temperature setting of your refrigerator to +4 °C.
- The temperature of the fridge compartment should be in the range of 0-8 °C, fresh foods below 0 °C are iced and rotted, bacterial load increases above 8 °C, and spoils.
- Do not put hot food in the refrigerator immediately, wait for the temperature to pass outside. Hot foods increase the degree of your refrigerator and cause food poisoning and unnecessary spoiling of the food.
- Meat, fish, etc. should be stored in the chiller compartment of the food, and the vegetable compartment is preferred for vegetables. (if available)
- To prevent cross-contamination, meat products and fruit vegetables are not stored together.
- Foods should be placed in the refrigerator in closed containers or covered to prevent moisture and odors.

The table below is a quick guide to show you the most efficient way to store the major food groups in your refrigerator compartment.

Food	Maximum storage time	How and where to store
Vegetables and fruits	1 week	Vegetable bin
Meat and fish	2 - 3 days	Wrap in plastic foil, bags, or in a meat container and store on the glass shelf
Fresh cheese	3 - 4 days	On the designated door shelf
Butter and margarine	1 week	On the designated door shelf
Bottled products e.g. milk and yoghurt	Until the expiry date recommended by the producer	On the designated door shelf
Eggs	1 month	On the designated egg shelf
Cooked food	2 days	All shelves



**NOTE:**

Potatoes, onions and garlic should not be stored in the refrigerator.

## 4.2 Freezer Compartment

The freezer is used for storing frozen food, freezing fresh food, and making ice cubes.

- Food in liquid form should be frozen in plastic cups and other food should be frozen in plastic folios or bags. For freezing fresh food; wrap and seal fresh food properly, that is the packaging should be air tight and shouldn't leak. Special freezer bags, aluminium foil polythene bags and plastic containers are ideal.
- Do not store fresh food next to frozen food as it can thaw the frozen food.
- Before freezing fresh food, divide it into portions that can be consumed in one sitting.
- Consume thawed frozen food within a short period of time after defrosting
- Always follow the manufacturer's instructions on food packaging when storing frozen food. If no information is provided food, should not be stored for more than 3 months from the date of purchase.
- When purchasing frozen food, make sure that it has been stored under appropriate conditions and that the packaging is not damaged.
- Frozen food should be transported in appropriate containers and placed in the freezer as soon as possible.
- Do not purchase frozen food if the packaging shows signs of humidity and abnormal swelling. It is probable that it has been stored at an unsuitable temperature and that the contents have deteriorated.
- The storage life of frozen food depends on the room temperature, the thermostat setting, how often the door is opened, the type of food, and the length of time required to transport the product from the shop to your home. Always follow the instructions printed on the packaging and never exceed the maximum storage life indicated.
- If the freezer door has been left open for a long time or not closed properly, frost will form and can prevent efficient air circulation. To resolve this, unplug the freezer and wait for it to defrost. Clean the freezer once it has fully defrosted.

- The freezer volume stated on the label is the volume without baskets, covers, and so on.
- Do not refreeze thawed food. It may pose a danger to your health and cause problems such as food poisoning.

**NOTE:**

If you attempt to open the freezer door immediately after closing it, you will find that it will not open easily. This is normal. Once equilibrium has been reached, the door will open easily.



The table below is a quick guide to show you the most efficient way to store the major food groups in your freezer compartment.

<b>Meat and fish</b>	<b>Preparation</b>	<b>Maximum storage time (months)</b>
Steak	Wrap in foil	6 - 8
Lamb meat	Wrap in foil	6 - 8
Veal roast	Wrap in foil	6 - 8
Veal cubes	In small pieces	6 - 8
Lamb cubes	In pieces	4 - 8
Minced meat	In packaging without using spices	1 - 3
Giblets (pieces)	In pieces	1 - 3
Bologna sausage/salami	Should be kept packaged even if it has a membrane	1 - 3
Chicken and turkey	Wrap in foil	4 - 6
Goose and duck	Wrap in foil	4 - 6
Deer, rabbit, wild boar	In 2.5 kg portions or as fillets	6 - 8
Freshwater fish (Salmon, Carp, Crane, Catfish)	After cleaning the bowels and scales of the fish, wash and dry it. If necessary, remove the tail and head.	2
Lean fish (Bass, Turbot, Flounder)		4
Fatty fishes (Tuna, Mackerel, Bluefish, Anchovy)		2 - 4
Shellfish	Clean and in a bag	4 - 6
Caviar	In its packaging, or in an aluminium or plastic container	2 - 3
Snails	In salty water, or in an aluminium or plastic container	3



**NOTE:** Thawed frozen meat should be cooked as fresh meat. If the meat is not cooked after defrosting, it must not be re-frozen.

<b>Vegetables and Fruits</b>	<b>Preparation</b>	<b>Maximum storage time (months)</b>
String beans and beans	Wash, cut into small pieces and boil in water	10 - 13
Beans	Hull, wash and boil in water	12
Cabbage	Clean and boil in water	6 - 8
Carrot	Clean, cut into slices and boil in water	12
Pepper	Cut the stem, cut into two pieces, remove the core and boil in water	8 - 10
Spinach	Wash and boil in water	6 - 9
Cauliflower	Remove the leaves, cut the heart into pieces and leave it in water with a little lemon juice for a while	10 - 12
Eggplant	Cut into pieces of 2 cm after washing	10 - 12
Corn	Clean and pack with its stem or as sweet corn	12
Apple and pear	Peel and slice	8 - 10
Apricot and Peach	Cut into two pieces and remove the stone	4 - 6
Strawberry and Blackberry	Wash and hull	8 - 12
Cooked fruits	Add 10 % of sugar to the container	12
Plum, cherry, sourberry	Wash and hull the stems	8 - 12

	<b>Maximum storage time (months)</b>	<b>Thawing time at room temperature (hours)</b>	<b>Thawing time in oven (minutes)</b>
Bread	4 - 6	2 - 3	4-5 (220-225 °C)
Biscuits	3 - 6	1 - 1,5	5-8 (190-200 °C)
Pastry	1 - 3	2 - 3	5-10 (200-225 °C)
Pie	1 - 1,5	3 - 4	5-8 (190-200 °C)
Phyllo dough	2 - 3	1 - 1,5	5-8 (190-200 °C)
Pizza	2 - 3	2 - 4	15-20 (200 °C)

<b>Dairy products</b>	<b>Preparation</b>	<b>Maximum storage time (months)</b>	<b>Storage conditions</b>
Packet (Homogenized) Milk	In its own packet	2 - 3	Pure Milk – in its own packet
Cheese - excluding white cheese	In slices	6 - 8	Original packaging may be used for short-term storage. Keep wrapped in foil for longer periods.
Butter, margarine	In its packaging	6	



## PART 5: CLEANING AND MAINTENANCE



Disconnect the unit from the power supply before cleaning.



Do not wash your appliance by pouring water on it.



Do not use abrasive products, detergents or soaps for cleaning the appliance. After washing, rinse with clean water and dry carefully. When you have finished cleaning, reconnect the plug to the mains supply with dry hands.

- Make sure that no water enters the lamp housing and other electrical components.
- The appliance should be cleaned regularly using a solution of bicarbonate of soda and lukewarm water.
- Clean the accessories separately by hand with soap and water. Do not wash accessories in a dish washer.
- Clean the condenser with a brush at least twice a year. This will help you to save on energy costs and increase productivity.



The power supply must be disconnected during cleaning.

### 5.1 Defrosting

#### Defrosting the Refrigerator Compartment

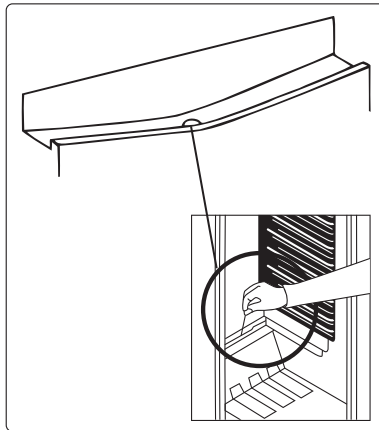

- Defrosting occurs automatically in the refrigerator compartment during operation. The water is collected by the evaporation tray and evaporates automatically.
- The evaporation tray and the water drain hole should be cleaned periodically with the defrost drain plug to prevent the water from collecting at the bottom of the refrigerator instead of flowing out.
- You can also clean the drain hole by pouring half a glass of water down it.

### Freezer defrosting process

- Small amounts of frost will accumulate inside the freezer, depending on the length of time the door may be left open or the amount of moisture introduced. It is essential to ensure that no frost or ice is allowed to form in places where it will affect the close fitting of the door seal. This might allow air to penetrate the cabinet, encouraging continuous running of the compressor. Thin frost formation is quite soft and can be removed with a brush or plastic scraper. Do not use metal or sharp scrapers, mechanical devices or other means to accelerate the defrosting process. Remove all dislodged frost from the cabinet floor. It is not necessary to switch off the appliance for the removal of thin frost.
- For the removal of heavy ice deposits, disconnect the appliance from the mains supply, empty the contents into cardboard boxes and wrap in thick blankets or layers of paper to keep cool. Defrosting will be most effective if carried out when the freezer is nearly empty and should be carried out as quickly as possible to prevent an unnecessary increase in the temperature of the contents.
- Do not use metal or sharp scrapers, mechanical devices or other means to accelerate the defrosting process. An increase in temperature of frozen food during defrosting will shorten the storage life. Keep contents well wrapped and cool while defrosting is taking place.

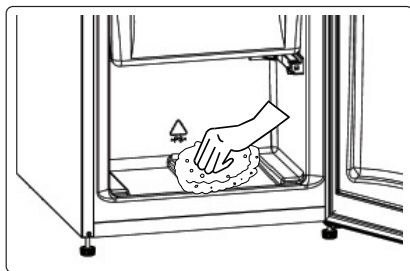

- Dry the inside of the compartment with a sponge or a clean cloth.
- To accelerate the defrosting process, place one or more bowls of warm water in the freezer compartment.
- Examine the contents when replacing them in the freezer and if some of the packages have thawed out, they should be eaten within 24 hours, or be cooked and re-frozen.
- After defrosting is complete, clean the inside of the appliance with a solution of warm water and a little bicarbonate of soda, then dry thoroughly. Wash all removable parts in the same way and reassemble. Reconnect the appliance to the mains supply and leave for 2 to 3 hours on setting number MAX before introducing the food back into the freezer.

## Replacing LED Lighting

To replace any of the LEDs, please contact the nearest Authorised Service Centre.



### Note:

The numbers and location of the LED strips may change according to the model.

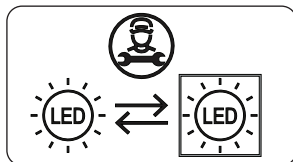

### If product equipped with LED lamp

This product contains a light source of energy efficiency class <E>.

### If product equipped with LED Strip(s) or LED card(s)

This product contains a light source of energy efficiency class <F>.

## PART 6: SHIPMENT AND REPOSITIONING

### 6.1 Transportation and Changing Positioning

- The original packaging and foam may be kept for re-transportation (optional).
- Fasten your appliance with thick packaging, bands or strong cords and follow the instructions for transportation on the packaging.
- Remove all movable parts or fix them into the appliance against shocks using bands when re-positioning or transporting.



Always carry your appliance in the upright position.

### 6.2 Repositioning the Door

- It is not possible to change the opening direction of your appliance door if door handles are installed on the front surface of the appliance door.
- It is possible to change the opening direction of the door on models with handle on the side of the door or without handles.
- If the door-opening direction of your appliance can be changed, contact the nearest Authorised Service Centre to change the opening direction.

## PART 7: BEFORE CALLING AFTER-SALES SERVICE

If you are experiencing a problem with your appliance, please check the following before contacting the after-sales service.

### Your appliance is not operating

#### Check if:

- There is power
- The plug is correctly placed in the socket
- The plug fuse or the mains fuse has blown
- The socket is defective. To check this, plug another working appliance into the same socket.

### The appliance performs poorly

#### Check if:

- The appliance is overloaded
- The appliance door is closed properly
- There is any dust on the condenser
- There is enough space near the rear and side walls.

### Your appliance is operating noisily

#### Normal noises

##### Cracking noise occurs:

- During automatic defrosting
- When the appliance is cooled or warmed (due to expansion of appliance material).

##### Short cracking noise occurs:

When the thermostat switches the compressor on/off.

##### Motor noise:

Indicates the compressor is operating normally. The compressor may cause more noise for a short time when it is first activated.

##### Bubbling noise and splash occurs:

Due to the flow of the refrigerant in the tubes of the system.

**Water flowing noise occurs:** Due to water flowing to the evaporation container. This noise is normal during defrosting.

**Air blowing noise occurs:** In some models during normal operation of the system due to the circulation of air.

### The edges of the appliance in contact with the door joint are warm

Especially during summer (warm seasons), the surfaces in contact with the door joint may become warmer during the operation of the compressor, this is normal.

### There is a build-up of humidity inside the appliance

#### Check if:

- All food is packed properly. Containers must be dry before being placed in the appliance.
- The **appliance** door is opened frequently.  
Humidity of the room enters the **appliance** when the doors are opened.  
Humidity increases faster when the doors are opened more frequently, especially if the humidity of the room is high.

## **The door does not open or close properly**

### **Check if:**

- There is food or packaging preventing the door from closing
- The door joints are broken or torn
- Your appliance is on a level surface.
- The compressor can run loudly or the noise of the compressor/refrigerator may increase in some models during operating in some conditions such that the product is plugged in for the first time, depending on change in the ambient temperature or change of usage. That is normal; when the refrigerator reaches the required temperature, the noise decreases automatically.

### **Recommendations**

- If the appliance is switched off or unplugged, wait at least 5 minutes before plugging the appliance in or restarting it in order to prevent damage to the compressor.
- If you will not use your appliance for a long time (e.g. in summer holidays) unplug it. Clean your appliance according to chapter cleaning and leave the door open to prevent humidity and smell.
- If a problem persists after you have followed all the above instructions, please consult the nearest authorised service centre.
- The appliance you have purchased is designed for domestic use only. It is not suitable for commercial or common use. If the consumer uses the appliance in a way that does not comply with this, we emphasise that the manufacturer and the dealer will not be responsible for any repair and failure within the guarantee period.

## **PART 8: TIPS FOR SAVING ENERGY**

1. Install the appliance in a cool, well ventilated room, but not in direct sunlight and not near a heat source (such as a radiator or oven) otherwise an insulating plate should be used.
2. Allow warm food and drinks to cool before placing them inside the appliance.
3. Place thawing food in the refrigerator compartment if available. The low temperature of the frozen food will help cool the refrigerator compartment while the food is thawing. This will save energy. Frozen food left to thaw outside of the appliance will result in a waste of energy.
4. Drinks or other liquids should be covered when inside the appliance. If left uncovered, the humidity inside the appliance will increase, therefore the appliance uses more energy. Keeping drinks and other liquids covered helps preserve their smell and taste.
5. Avoid keeping the doors open for long periods and opening the doors too frequently as warm air will enter the appliance and cause the compressor to switch on unnecessarily often.
6. Keep the covers of the different temperature compartments (such as the crisper and chiller if available) closed.
7. The door gasket must be clean and pliable. In case of wear, replace the gasket.

# PART 9: PRODUCT INFORMATION SHEET

## Product Information Sheet

**PHILCO** 

COMMISSION DELEGATED REGULATION (EU) 2019/2016 with regard to energy labelling of refrigerating appliances

**Supplier's name or trademark:** PHILCO

**Supplier's address:** PHILCO, U Sanitasu 1621, 25101 Říčany, CZ

**Model identifier:** PT 168 EMW, PT 168 EMX

### Type of refrigerating appliance:

Low-noise appliance:	No	Design type:	freestanding
Wine storage appliance:	No	Other refrigerating appliance:	Yes

### General product parameters:

Parameter	Value	Parameter	Value
Overall dimensions (millimetre)	Height	Total volume (dm <sup>3</sup> or l)	167
	Width		
	Depth		
Energy efficiency Index (EEL)	100	Energy efficiency class*	E
Airborne acoustical noise emissions (dB(A) re 1 pW)	40	Airborne acoustical noise emission class	C
Annual energy consumption (kWh/a)	180	Climate class:	temperate, subtropical
Minimum ambient temperature (°C), for which the refrigerating appliance is suitable	16	Maximum ambient temperature (°C), for which the refrigerating appliance is suitable	38
Winter setting	Yes		

### Compartment Parameters:

Compartment type	Compartment parameters and values				
	Compartment volume (dm <sup>3</sup> or l)	Recommended temperature setting for optimised food storage (°C) These settings shall not contradict the storage conditions set out in Annex IV, Table 3	Freezing capacity (kg/24h)	Defrosting type (auto-defrost=A, manual defrost=M)	
Pantry	No	-	-	-	-
Wine storage	No	-	-	-	-

Cellar	No	-	-	-	-
Fresh food	Yes	126.0	4	-	A
Chill	No	-	-	-	-
0-star or ice-making	No	-	-	-	-
1-star	No	-	-	-	-
2-star	No	-	-	-	-
3-star	No	-	-	-	-
4-star	Yes	41.6	-18	2.6	M
2-star section	No	-	-	-	-
Variable temperature compartment	-	-	-	-	-
<b>For 4-star compartments</b>					
Fast freeze facility			Yes		
<b>Light source parameters:</b>					
Type of light source			LED		
Energy efficiency class			E		
<b>Minimum duration of the guarantee offered by the manufacturer:</b> 24 months					
<b>Additional information:</b>					
<b>Weblink to the manufacturer's website, where the information in point 4(a) Annex of Commission Regulation (EU) 2019/2019 is found:</b> <a href="http://www.philco.cz">www.philco.cz</a>					

## TECHNICAL INFORMATION

Technical information can be found on the type plate on the inside of the appliance and on the energy label. The QR code, on the supplied energy label, contains a link to register the appliance in the EU Eprel database. Keep the energy label, the instructions for use, together with other documents supplied with the device.

## TESTING INFORMATION

The delivered device is in accordance with Ecodesign a EN 60704-2-14/EN 60704-3 + EN62552-1/2/3:2020. Air access requirements for proper operation of the device, the minimum distance from the wall and the dimensions of the device are part of this manual. If you have any further questions, please contact the manufacturer.

## CUSTOMER CARE AND SERVICE

Always use original spare parts.

Model name and serial number can be found on the rating plate. Position of rating plate can be changed without notice.

The original spare parts for some specific components are available for a minimum of 7 or 10 years, based on the type of component, from the placing on the market of the last unit of the model.

When contacting our authorized service, have the model designation, serial number and defect description available.

To download documents, visit [www.philco.cz](http://www.philco.cz).

To report a defect and obtain additional service information, visit <https://philco.cz/podpora-a-servis>.

Subject to change without notice.



## INSTRUCTIONS AND INFORMATION REGARDING THE DISPOSAL OF USED PACKAGING MATERIALS

Dispose of packaging material at a public waste disposal site.

### DISPOSAL OF USED ELECTRICAL AND ELECTRONIC APPLIANCES



The meaning of the symbol on the product, its accessory or packaging indicates that this product shall not be treated as household waste. Please, dispose of this product at your applicable collection point for the recycling of electrical & electronic equipment waste. Alternatively in some states of the European Union or other European states you may return your products to your local retailer when buying an equivalent new product. The correct disposal of this product will help save valuable natural resources and help in preventing the potential negative impact on the environment and human health, which could be caused as a result of improper liquidation of waste. Please ask your local authorities or the nearest waste collection centre for further details. The improper disposal of this type of waste may fall subject to national regulations for fines.

#### **For business entities in the European Union**

If you wish to dispose of an electrical or electronic device, request the necessary information from your seller or supplier.

#### **Disposal in other countries outside the European Union**

If you wish to dispose of this product, request the necessary information about the correct disposal method from local government departments or from your seller.







This product meets all the basic EU regulation requirements that relate to it.

Changes to the text, design and technical specifications may occur without prior notice and we reserve the right to make these changes.

The English version of the manual is a translation of the original operating manual, which is in Czech.

**Dear customer,**  
**Thank you for buying a PHILCO brand product. So that your appliance serves you well, please read all the instructions in this user's manual.**

<b>Icon</b>	<b>Type</b>	<b>Meaning</b>
	WARNING	Serious injury or death risk
	RISK OF ELECTRIC SHOCK	Dangerous voltage risk
	FIRE	Warning; Risk of fire / flammable materials
	CAUTION	Injury or property damage risk
	IMPORTANT	Operating the system correctly





Výrobce/Manufacturer:  
Fast ČR, a.s.  
U Sanítasu 1621  
Říčany 251 01, CZECH REPUBLIC

Distributor:  
FAST PLUS, a.s.  
Vlčie hrdlo 324/90  
821 07 Bratislava, SLOVAKIA

Distributor:  
FAST POLAND Sp. z o. o.  
Kwietniowa 36  
05-090 Wypędy, POLAND

Distributor:  
FAST HUNGARY Kft.  
H-2310 Szigetszentmiklós  
Kántor utca 10, HUNGARY

**PHILCO**<sup>®</sup> 

**is pending or registered trademark of Electrolux Home  
Products, Inc. and used under a license from Electrolux  
Home Products, Inc**