

SENCOR®

SFT 3107WH / SFT 3108BK



TOWER FAN

Translation of the original manual



SENCOR®

SFT 3107WH / SFT 3108BK



A

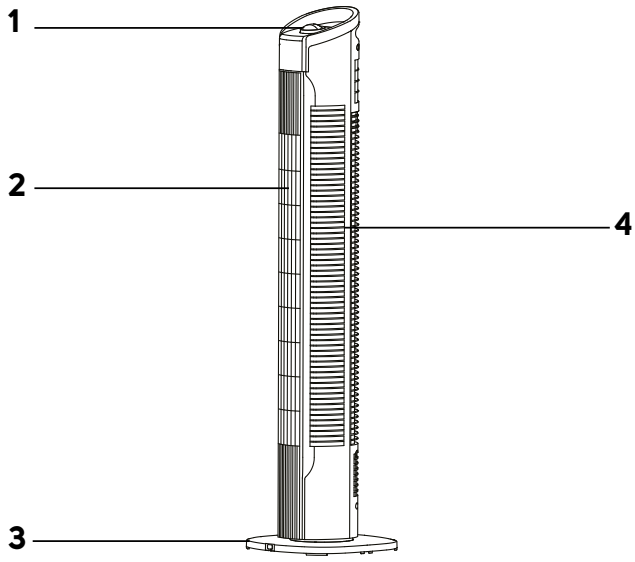

B1

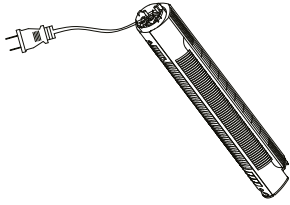

B2



B3

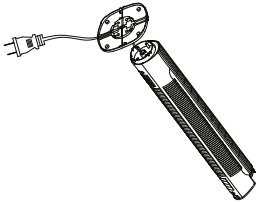

B4

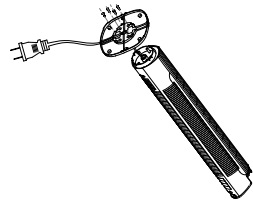

EN Tower Fan

Important safety instructions

READ CAREFULLY AND STORE FOR FUTURE USE

- This appliance may be used by children 8 years of age and older and by persons with physical or mental impairments or by inexperienced persons, if they are properly supervised or have been informed about how to use the product in a safe manner and understand the potential dangers.
 - Children must not play with the appliance. Cleaning and maintenance performed by the user must not be performed by unsupervised children.
 - In the event that the power cord is damaged, have it repaired at a professional service centre to prevent causing a dangerous situation. It is forbidden to use the appliance if it has a damaged power cord.
 - The fan is not intended to be mounted on external windows or walls.
-
- Before connecting the appliance to a power socket, check that the rated voltage on its rating label matches the electrical voltage in the power socket.
 - Connect the appliance only to a properly grounded socket. Do not use an extension cord.
 - The power socket must remain easily accessible for the event of a need of sudden disconnection.
 - The appliance is designed for use at home, in offices and similar types of areas. Do not use it in very dusty or humid rooms such as laundries or bathrooms, in areas where chemical or explosive substances are stored, in industrial surroundings or outdoors!
 - Do not place the appliance in the vicinity of an open flame or appliances that are sources of heat.
 - Prevent the fan, the power cord and the power plug from coming into contact with a hot surface.
 - Do not use this appliance with a programmable switch, timer switch, a remote control system or any other component that would automatically switch the appliance on and off.
 - To prevent injury by electrical shock, do not submerge the fan, the power cord or the power plug in water or any other liquid or rinse these under running water.
 - Always turn off the appliance and disconnect it from the power socket when leaving it without supervision, when not using it and before assembling, disassembling or cleaning it.
 - Do not touch the appliance with wet or damp hands or when standing on a wet floor.
 - Do not carry the appliance by the power cord. Always hold the body of the appliance with both hands.
 - Make sure that the appliance is correctly assembled before using it.

- Disconnect the appliance from the power socket by pulling on the plug, never pulling on the power cord. Otherwise, this could damage the power cord or the socket.
- Make sure that the power cord does not hang over the edge of a table or that it is not touching a hot surface. Do not place the appliance on unstable surfaces such as carpets with very long and thick fibres. Only place the the appliance on a clean, even, dry and smooth surface.
- Do not subject children, older persons or persons that are bed-bound to the effects of flowing cold air for an extended period of time.
- Do not cover the appliance with any items while it is running.
- Never insert your fingers or other items through the protective grille when the appliance is plugged into a power socket. This applies particularly when the appliance is in operation.
- Do not use the appliance if it is not working correctly, if it has been damaged or has been submerged in water. To avoid a hazardous situation arising, do not repair the appliance yourself or modify it in any way. Have all repairs performed at an authorised service centre. By tampering with the appliance, you risk voiding your legal rights arising from unsatisfactory performance or quality warranty.

EN Tower Fan

User's manual

- Prior to using this appliance, please read the user's manual thoroughly, even in cases, when one has already familiarised themselves with previous use of similar types of appliances. Only use the appliance in the manner described in this user's manual. Keep this user's manual in a safe place where it can be easily retrieved for future use.
- We recommend saving the original cardboard box, packaging material, purchase receipt and responsibility statement of the vendor or warranty card for at least the duration of the legal liability for unsatisfactory performance or quality. In the event of transportation, we recommend that you pack the appliance in the original box from the manufacturer.

DESCRIPTION OF THE FAN

- A1** Rotating speed control
A2 Air outlets
A3 Base
A4 Air inlets

INSTALLING THE BASE

The fan is supplied from the factory with a disassembled base.

1. Take the body of the fan out of the packaging material and carefully turn it upside down – see figure **B1**.
2. Place both parts of the base **A3** against the bottom part of the body of the fan. Check that the power cord passes through the hole in the middle of the base **A3** – see figure **B2**.
3. Carefully push both parts of the base **A3** until they click into the body of the fan – see figure **B3**.
4. Using the supplied bolts, secure the base **A3** in place – see figure **B4**.

USING THE FAN

Place the fan on a horizontal, stable, dry and smooth surface within reach of a power socket. Connect the power cord to a power socket.

1. Turn the control **A1** to the right and select the required speed 1 (lowest speed) – 2 (medium speed) – 3 (highest speed).
2. Turn the control **A1** to the left and select the required speed: 1 (lowest speed) – 2 (medium speed) – 3 (highest speed) together with the left-right oscillation of the fan body.
3. In the event that you need to turn off the fan, turn the control **A1** up or down until it shows "0".

CLEANING AND MAINTENANCE

Before cleaning it, make sure that the fan is turned off and disconnected from the power socket. Clean the fan regularly to ensure its long lifetime. For cleaning, do not use cleaning products with an abrasive effect, solvents, etc. that could damage the appliance.



Warning:

To prevent the risk of injury by electrical shock, do not submerge the appliance, power cord or power plug in water or any another liquid.

To clean the outer surface of the of the fan, use a clean, lightly dampened cloth. Then wipe everything so that it is thoroughly dry. Ensure that moisture does not enter through the air inlets or outlets into the fan. You can also remove any dirt inside the air inlet or outlet by using a vacuum cleaner with a bristle brush.



Note:

Regularly check that the bolts on the base **A3** are securely tightened.

STORAGE

If you will not be using the fan for a longer period of time, store it in a clean, dry location that is out of reach of children.

TECHNICAL SPECIFICATIONS

Rated voltage range.....	220–240 V ~
Rated frequency.....	50 Hz
Rated power input.....	50 W
Noise level.....	56 dB(A)
Maximum air flow of the fan.....	7.38 m ³ /min
Operation value.....	0.2 (m ³ /min)/W
Maximum air flow speed.....	0.68 m/s
Norm for measuring the operating value.....	EN ISO 5801:2008
Contact for further information.....	

.....FAST ČR, a.s., U Sanitáru 1621, 251 01 Říčany, Czechia
The declared noise emission level for fan model SFT 3107WH / SFT 3108BK is 56 dB(A), which represents a level A of acoustic power with respect to a reference acoustic power of 1 pW.
We reserve the right to change text and technical specifications.



Safety class for electrical shock protection:
Class II – Electrical shock protection is provided by double or heavy-duty insulation.

INSTRUCTIONS AND INFORMATION REGARDING THE DISPOSAL OF USED PACKAGING MATERIALS

Dispose of used packaging material at a site designated for waste in your municipality.

DISPOSAL OF USED ELECTRICAL AND ELECTRONIC EQUIPMENT



This symbol on products or original documents means that used electric or electronic products must not be added to ordinary municipal waste. For proper disposal, renewal and recycling hand over these appliances to determined collection points. Alternatively, in some European Union states or other European countries you may return your appliances to the local retailer when buying an equivalent new appliance. Correct disposal of this product helps save valuable natural resources and prevents potential negative effects on the environment and human health, which could result from improper waste disposal. Ask your local authorities or collection facility for more details. In accordance with national regulations penalties may be imposed for the incorrect disposal of this type of waste.

For business entities in European Union states

If you want to dispose of electric or electronic appliances, ask your retailer or supplier for the necessary information.

Disposal in other countries outside the European Union.

This symbol is valid in the European Union. If you wish to dispose of this product, request the necessary information about the correct disposal method from the local council or from your retailer.



This product meets all the basic requirements of EU directives related to it.

