



**FIELDMANN**<sup>®</sup>  
Home & Garden Performance

**20V** LITHION  
**FASTPOWER**



FZR 70385-0

---

English .....	1-24
Čeština.....	26-42
Slovenčina .....	43-60
Magyarul .....	61-78
Polski .....	79-96

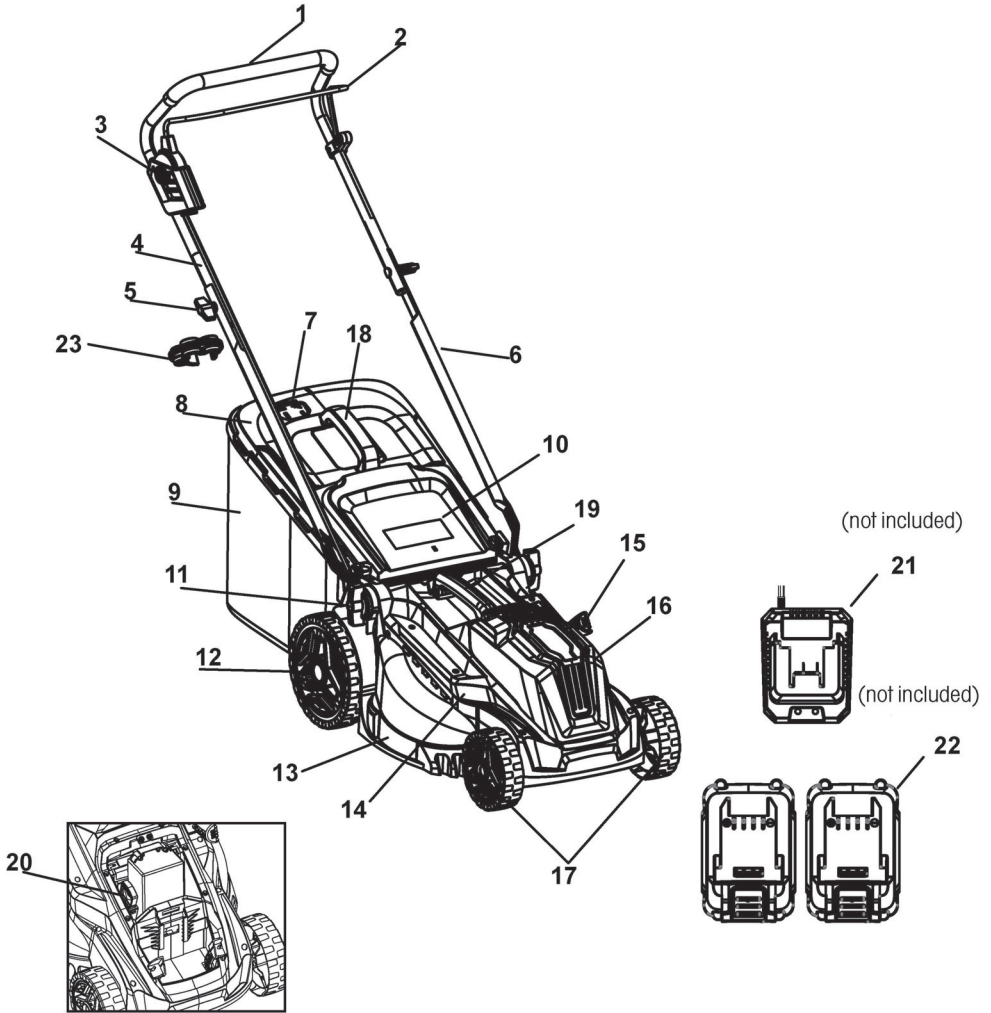

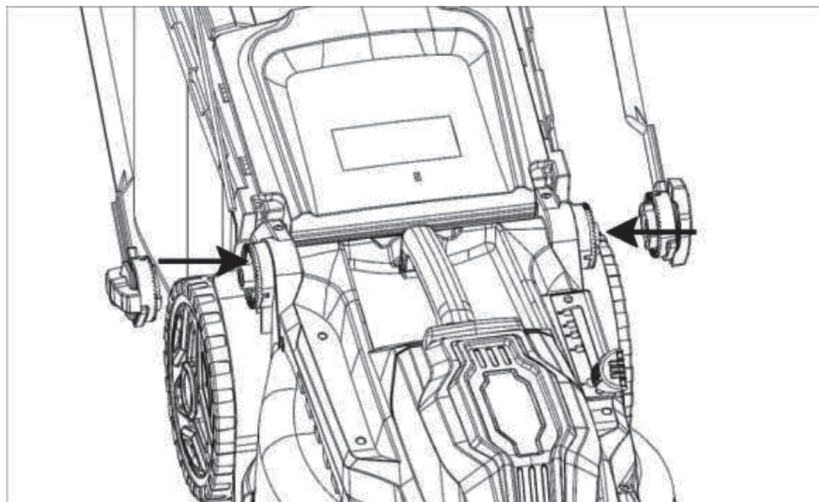

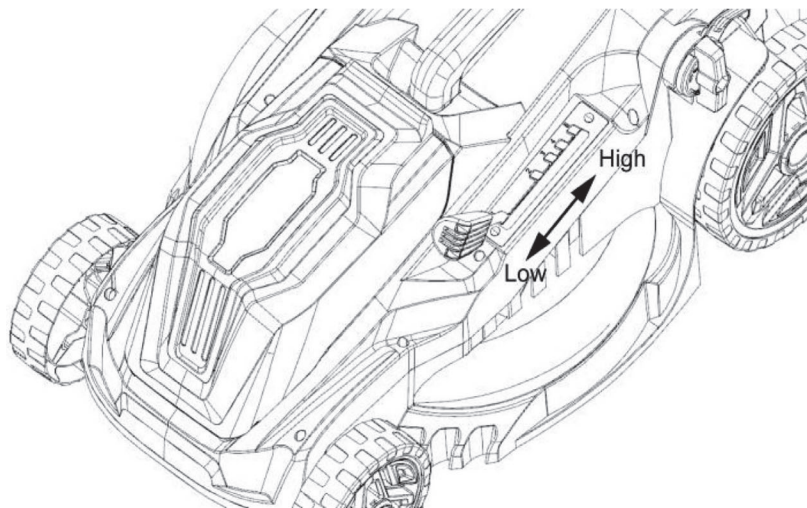

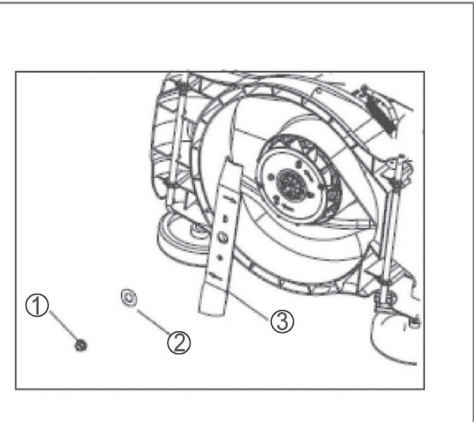
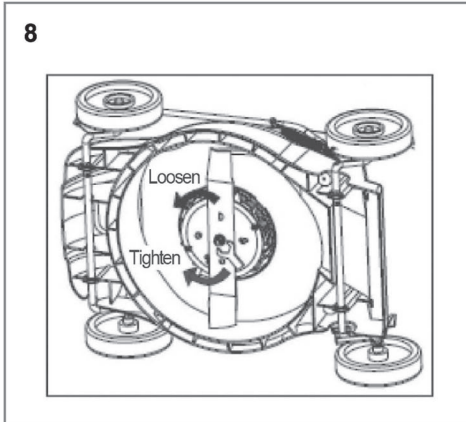
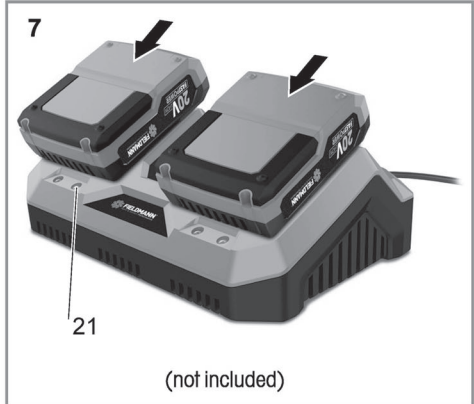
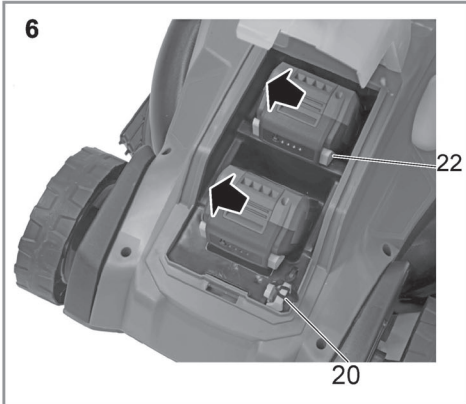
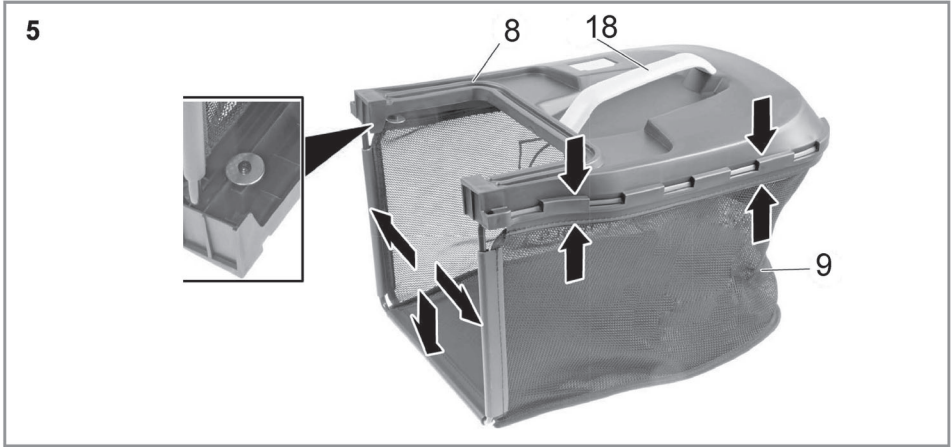

# CORDLESS LAWN MOWER 38CM

## INSTRUCTIONS FOR USE

**Thank you for purchasing this cordless lawn mower.  
Before you start using it, please read this user manual carefully and save it for future use.**

### TABLE OF CONTENTS

Instructions for use .....	7
1. GENERAL SAFETY REGULATIONS.....	8
2. SYMBOLS .....	9
3. DESCRIPTION.....	10
4. BASIC WORK SAFETY .....	10
5. ASSEMBLY AND OPERATION.....	14
7. TECHNICAL SPECIFICATIONS.....	21
8. TROUBLESHOOTING.....	22
9. MAINTENANCE .....	23
10. DISPOSAL .....	24

# 1. GENERAL SAFETY REGULATIONS

## IMPORTANT SAFETY NOTICE

- ✿ Unpack the product carefully and do not throw away any of the packaging until you have found all the parts of the product.
- ✿ Store the product in a dry place out of reach of children.
- ✿ Read all the warnings and instructions. Failure to comply with the warnings and instructions may lead to electric shock, fire and/or serious injuries.

## PACKAGING

The product's packaging prevents damage during transport. This packaging is a resource and can be recycled.

## USER MANUAL

Before starting to work with the machine, please read the following safety regulations and instructions for use. Get familiar with the controls and correct use of the equipment. Keep the user's manual in a safe place for easy future reference. Save the original packaging, including the internal packing material, guarantee card and proof of purchase receipt for at least the time of the guarantee. If you need to transport this power tool, pack it in the original cardboard box for maximum protection during shipping or transport (e.g. when moving or when you need to send this power tool to a service centre for repair).

 **Note:** If you hand over the appliance to somebody else, do so together with this user's manual. Make sure you use the appliance properly by following the instructions in the included User manual. The user's manual also contains operating, maintenance, and repair instructions.

**The manufacturer assumes no responsibility for accidents or damages arising from failure to comply with these instructions.**



## 2. SYMBOLS



**Risk of injury due to cutting mechanism!**  
**Never reach into the cutting mechanism.**



**Use eye protection.**



**Observe the safety instructions before using the product for the first time.**



**Use ear protection.**



**Keep other persons in distance!**  
**WARNING! When operating the device, take care that no other persons are nearby (safe distance: 5m).**  
**This is particularly valid for children and animals.**



**Be careful of the sharp blade edges.**



**Danger of injury!**  
**Beware of hurled-away objects.**  
**Keep bystanders away.**



**Be careful of the sharp blade edges. The blades continue to rotate even after the motor is turned off.**



**Read the Instruction Manual attentively prior to use.**



**Protect the tool from the damp and never expose it to rain!**



**Guaranteed sound power level Lwa 96 dB (A)**



**Before doing any maintenance and repair work disconnect the circuit breaker from the lawn mower.**

### 3. DESCRIPTION

1. Grip handle with foam
2. Start lever
3. Switch box
4. Upper handle
5. Wing nut (x2)
  - a. Washer (x2)
  - b. Mounting bolt (x2)
6. Lower handle
7. Grass indicator
8. Grass collector top cover
  - a. Frame of grass collector
  - b. Screws (x1)
9. Grass bag
10. Rear flap
11. Handle support assembly
  - a. Angle adjustment wheel (x2)
  - b. Screw (x4)
  - c. Fix wheel (x2)
  - d. Screw with washer assembly (x4)
12. Rear wheel (x2)
  - Rear wheel cap (x2)
13. Deck
14. Upper cover
15. Lever for cutting height adjustment
16. Battery cover
17. Front wheel (x2)
  - Front wheel cap (x2)
18. Grass collector handle
19. Carry handle
20. Safety key
21. Charger (not included)
22. Battery pack (not included)
23. Wire clip

### 4. BASIC WORK SAFETY

#### IMPORTANT ACCUMULATOR SAFETY INSTRUCTIONS

- ⚠ Batteries are a chemical source of electrical energy, containing chemical compounds that can cause injury to health, property or the environment. Therefore, handle them with caution.
- ⚠ The battery is ready to supply power at any time, even in undesirable circumstances!
- ⚠ **ATTENTION!** even with a partially charged battery, a short circuit may occur and damage it. In the worst case, it may cause an explosion or fire. Therefore, always treat batteries in a way that prevents short circuits (e.g. with paper clips, coins, keys, nails, screws or other small metal objects)!  
Even when stored.
- ⚠ Use only batteries recommended by the device manufacturer.
- ⚠ The battery must not be stored or operated near an open flame. It must also not be thrown into the fire.
- ⚠ Do not dispose of old batteries into regular household waste.
- ⚠ Also, never touch the blades until the machine is disconnected from the power source and until the blades completely stop.
- ⚠ Disconnect the device from the power supply (i.e. remove the battery from the machine):
  - If you need to leave the machine without supervision
  - If you have to leave the machine unsupervised
  - Before every inspection, every cleaning or repairs
  - If you hit a foreign body when working with it
  - If the machine vibrates excessively.
- ⚠ Read carefully the basics of working safely with the machine and the user's manual.
- ⚠ This machine must not be operated by anyone with limited physical, sensory or mental abilities (including

children). Furthermore, it must not be used by inexperienced people who do not have the technical knowledge to operate it. These people must be supervised by a competent person or instructed about the basics of work safety.

- ✿ If children are near the machine, make sure they do not play with it.
- ✿ Tingling or numb hands are indications of excessive vibrations.  
If this happens, shorten the work cycle, take sufficiently long breaks, share the work among several people or if the lawnmower is used for long periods wear special anti-vibration gloves.
- ✿ An unavoidable consequence of using the lawnmower is the noise when it is running. Therefore, only do noisy work during dedicated hours, or when this type of activity is normal. Respect quiet times and try to limit the work to the shortest possible time.  
We also recommend that you and persons near the lawnmower wear ear protectors.

### IMPORTANT SAFETY INSTRUCTIONS FOR BATTERY CHARGER

**⚠ ATTENTION!** Danger of injury by electric shock!

**⚠ ATTENTION!** Check the charger, cable and plug before each use. If damage is found, the charger must not be used.

**⚠ ATTENTION!** Before use, read all instructions and warnings on the charger and battery case.

- ✿ Do not expose the charger to rain, snow or moisture. The entry of water into the battery charger increases the danger of injury by electrical shock.
- ✿ To reduce the risk of damage to the plug and the power cord, always unplug the power cord by pulling on the plug (never pull the cord).
- ✿ Make sure that the cable is positioned so that no one is stepping on it, that no one trips over it or is otherwise damaged.
- ✿ Never charge the battery in an explosive atmosphere and near flammable substances. in a flammable environment. Do not operate on lightly flammable surfaces (e.g. paper, textiles, etc.).
- ✿ Do not disassemble the charger. If it needs to be replaced or repaired, take it to an authorized service centre. Failure to do so may result in electric shock or fire.
- ✿ NEVER store or use the charger in places where the temperature may reach or exceed 50° C (such as porches, cars, etc.).
- ✿ Check that the mains voltage is within the range required by the charger manufacturer. The circuit must be adequately current protected.

### OTHER RISKS

**⚠ ATTENTION!** In the event of mechanical damage to the battery compartment, avoid contact with chemicals that may leak from it. In case of contact with chemicals, rinse immediately with clean water. In case of extensive contact or chemical burn or eye contact, seek medical attention as soon as possible.

- ✿ Despite our products being designed to meet the valid technical standards and safety directives, there are still some risks to the user from using the machine:
  - Stones and other fragments may fly out of the mowing deck.
  - If the machine operator does not use ear protectors, then they risk subsequent deafness.
  - Injured fingers during blade maintenance
  - Inhaling grass clipping particles

- Electric shock from un-insulated parts.
- ✿ This machine must not be operated by those with limited physical, sensory or mental abilities (including children) or inexperienced persons or persons whose technical knowledge is evidently insufficient for the given task; and these people should only operate the device under the supervision of a person that is competent for this task or where the person is thoroughly instructed in working safely with the machine.
- ✿ If children are near the machine, make sure they do not play with it.

**⚠ ATTENTION!** Carefully read the user manual before using this lawn mower. Make sure that you thoroughly know all the control elements. Following the work safety rules for the machine minimises the risk of fire, electric shock or other injuries.

- ✿ Keep the user manual carefully in case it is needed.
- ✿ If the machine is incorrectly operated it could cause an injury. The lawnmower could cause serious injury to the user and those nearby and therefore these work safety rules should always be followed to eliminate this risk if possible.  
The user is responsible for safety when working with the machine. Never use the machine if any of its safety items are missing or not in full working order.

### BEFORE YOU START USING THE LAWN MOWER

- ✿ Carefully read all the instructions provided in this user manual. Thoroughly get to know the machine's control elements and the basics for correct use.
- ✿ Never let children or anyone who you are not certain know the controls and the work safety rules for this machine operate it on their own. The national legislation may also stipulate a minimum age limit for operating this type of machine. Please read the laws governing this area in your country.
- ✿ Never use the lawnmower if people, particularly children or household pets, are moving nearby.
- ✿ Always remember that the user is fully responsible for injuries or damage to property caused by operating this machine.

### PREPARING FOR OPERATION

- ✿ When working with the machine wear suitable footwear and long trousers. Never operate the lawnmower barefooted or in sandals.
- ✿ Before starting work, inspect the ground and remove any items that could be deflected by the machine.

**⚠ ATTENTION!** Before every use of the machine, make sure that the blade, its mounting pin and the lawn mower body in general is not damaged or excessively worn. Always replace a damaged or worn out part, of which there are sets on the machine, with an entire set to prevent imbalance.

### OPERATION

- ✿ Only operate the machine during daylight or sufficient artificial lighting.
- ✿ If possible, do not mow wet grass.
- ✿ Make sure that during work you always have a firm support and a secure stance.
- ✿ Do not run when pushing the mower - walk normally.
- ✿ The following general rules apply for work with the lawn mower: When mowing on a slope, do not move up

and down but always along the contours, i.e. horizontally perpendicular to the incline of the slope.

- ✿ Be very careful when changing direction on a slope.
- ✿ Never use the lawn mower on extremely steep slopes.
- ✿ If you need to pull the lawnmower towards you while it is running or if you need to move backwards with the lawnmower, be very careful.
- ✿ Always stop the blades from turning when transporting the machine or moving over an un-grassed area.
- ✿ Never use the machine if any covers are damaged or if any of its safety elements are missing such as deflectors or grass catchers.
- ✿ Always start the motor as described in the user manual, and make sure to keep your feet away from the blades.
- ✿ Never tilt the machine when starting the motor unless it is really essential to start it. In this case, turn the side of the lawnmower that is farther away from you upwards.
- ✿ Never put your hands or feet under the lawnmower, in particular near to the moving parts. Never cover the grass ejection chute.
- ✿ Never transport the machine if the motor is still running.
- ✿ Always stop the engine first and remove the battery from the machine; only then can the faults be removed or the grass catcher be emptied.
  - Proceed in the same way before every inspection, cleaning or repair of the machine.
  - If you hit a foreign body make sure the lawnmower has not been damaged, and if it has repair the damage before starting the motor again.
  - Or if the machine starts to vibrate more than unusual (immediately check the machine!)
- ✿ Stop the motor whenever you move away from the machine.

## **MAINTENANCE AND STORAGE**

- ✿ Always make sure that all nuts, pins and bolts are securely tightened so that the machine operates safely.
- ✿ Regularly check the grass catcher for damage or excessive wear and tear.
- ✿ Immediately replace worn out or damaged parts. This will help your lawnmower to operate safely.
- ✿ When setting adjustable elements, take care not to clamp your fingers between the moving blades and the fixed part of the machine. Let the motor cool down before storing the lawnmower in an enclosed area.

## 5. ASSEMBLY AND OPERATION

### UNPACKING

- ✿ Unpack all parts and lay them on a flat, stable surface.
- ✿ Remove all packing materials and shipping devices if applicable.
- ✿ Make sure the delivery contents are complete and free of any damage. If you find that parts are missing or show damage do not use the product but contact your dealer. Using an incomplete or damaged product represents a hazard to people and property.
- ✿ Ensure that you have all the accessories and tools needed for assembly and operation. This also includes suitable personal protective equipment.

**⚠ WARNING!** The product and the packaging are not children's toys!  
Children must not play with plastic bags, sheets and small parts! There is a danger of choking and suffocation!

### YOU WILL NEED / BEFORE YOU START

(items not supplied)

Suitable personal protective equipment

Suitable cross-head driver

Suitable wrench

battery pack (22) and battery charger (21)

(items supplied)

Grass collector (7,8,9,18)

 **Note:** The accessories required depend on the intended application. Ask your dealer for advice.

 **Note:** Parts marked with \* are not shown in this overview. Please refer to the respective part in the instruction manual.

### SET UP

**⚠ WARNING!** Do not use a product that is only partly assembled or assembled with damaged parts!  
Follow the assembly instructions step-by-step and use the pictures provided as a visual guide to easily assemble the product!  
Do not connect the product to battery pack (22) before it is completely assembled!

 **Note:** Take care of small parts that are removed during assembly or when making adjustments. Keep them secure to avoid loss.

## LOWER HANDLE

- ✿ Put the main unit (13) on the ground.
- ✿ Connect the lower handle (6) with the Handle support assembly (11): mount a angle adjustment wheel (11-a) to the lower handle (6) with 2 screws (11-b). The lower handle (6) is fixed on the main unit (13) through the engagement of a angle adjustment wheel (11-a) and a fixed wheel (11-c).

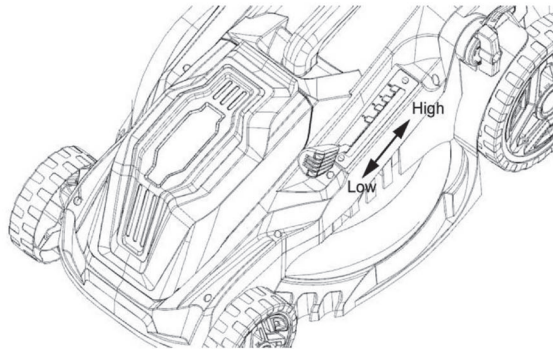

## UPPER HANDLE

- ✿ Hold the upper handle (1) with the start lever (2) facing upwards. Align the mounting holes of the upper handle (1) and the lower handle (6).
- ✿ Pass the mounting bolts (5-b) through the mounting holes of the upper handle (1) and the lower handle (6), washer (5-a) to the end, fasten the bolt (5-b) with the wing nut (5).
- ✿ Make sure the electrical cord run on the handles.
- ✿ Fix the electrical cord with the wire clip (23) on the lower handles (6).

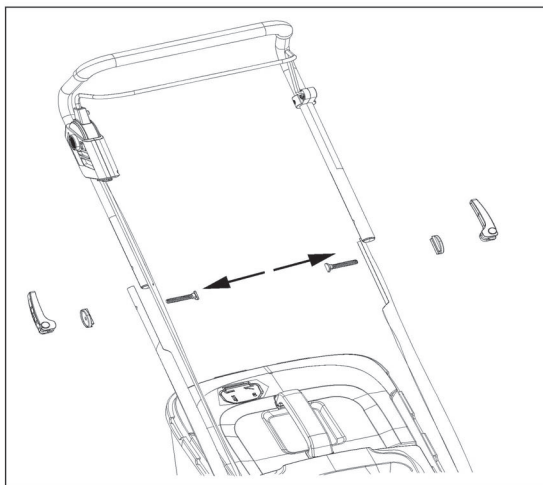

## GRASS CATCHER

- ✿ Match the grass bag (9) with grass frame (8-a), and insert the grass collector handle (18) into the top cover (8), with a screw (8-b) to fasten.
- ✿ Open the rear flap (10) and hold it in position.
- ✿ Carefully release the rear flap(10) afterwards.

 **Note:** Always carry the grass collector by its handle (18).

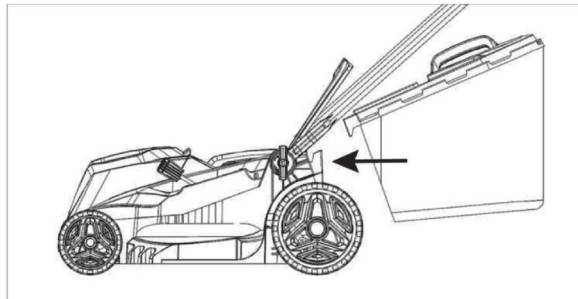
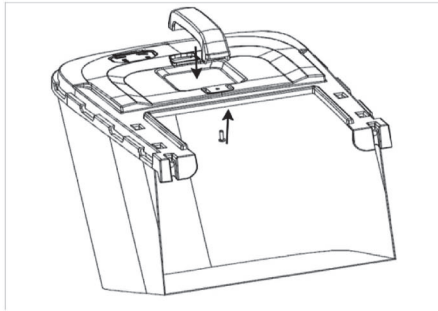

## BATTERY PACK ATTACHING THE BATTERY PACK

- ✿ Pull open the battery cover (16).
- ✿ Unplug the safety key (20) and keep it hanging by its string .
- ✿ Slide the battery pack (22) into the slots of the battery compartment.
- ✿ Make sure that the electrical contacts are fully inserted into the battery pack (22) and that it snaps in place with a click.
- ✿ The battery pack (22) can only be installed in one direction.
- ✿ Reinstall the safety key (20) into its slot .
- ✿ Close the battery cover (16) .



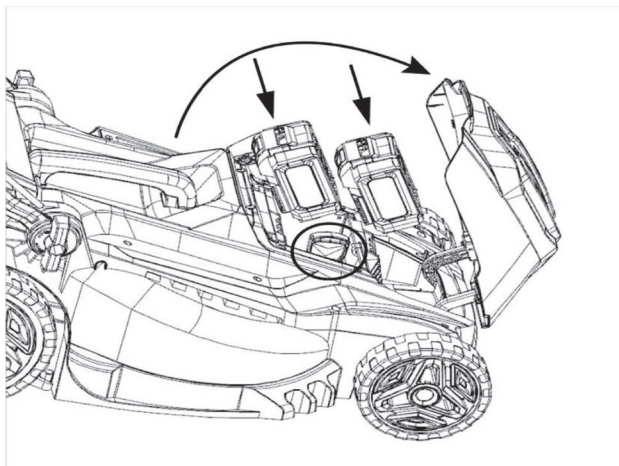

### RELEASING THE BATTERY PACK

The battery pack (22) can't be charged whilst in the mower. Remove the battery pack (22) from its battery compartment or spare battery compartment for charging.

- ✿ Pull open the battery cover (16).
- ✿ Squeeze the release button to unlock the latch of battery pack (22).
- ✿ Slide out the battery pack (22) from the battery compartment.
- ✿ Close the battery cover (16).

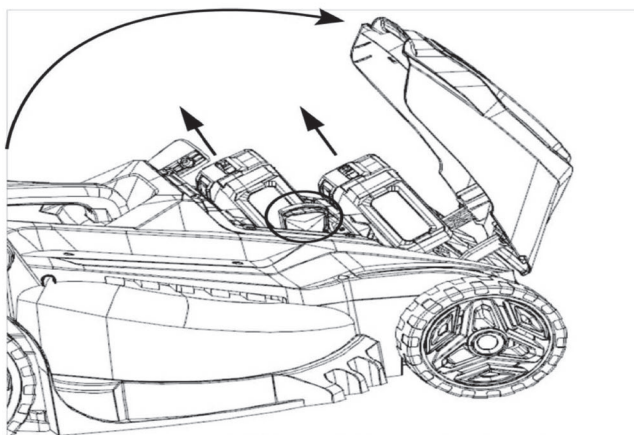

### CHARGING THE BATTERY PACK

The battery pack (22) for this product has been shipped in a low charge condition. Charge it fully before first use.

## CONNECT BATTERY PACK

- ✿ Make sure the start lever (2) is released and safety switch button is not pressed.
- ✿ Attach the battery pack (22) to the product. Ensure it snaps in place.
- ✿ Insert the safety key (20) into its slot fully.
- ✿ Your product is now ready to be used.

## INTENDED USE

This cordless lawn mower is designated with a rated voltage of 40V . It is designed only to be used with the battery pack which is listed in the chapter of "Technical specifications".

The product is intended for mowing grass in domestic gardens only.

It must not be used to mow unusually high, dry or wet grass, e.g. pasture grass, or to shred leaves. For safety reasons it is essential to read the entire instruction manual before first operation and to observe all the instructions therein. This product is intended for private domestic use only, not for any commercial trade use. It must not be used for any purposes other than those described.

## CUTTING HEIGHT ADJUSTMENT

 **Note:** There are 5 cutting height levels (30-75mm) available.

 **WARNING!** Switch the product off and wait that the cutting blade had come to a complete stop before adjusting the cutting height! Remove the safety key (20) before adjusting the cutting height!

Adjust the cutting height according to the needs of your lawn. The cutting height depends on the kind of lawn and its actual height. When mowing high grass, start with the maximum cutting height and make a second cut with a lower cutting height.

- ✿ Pull the lever (15) towards the rear wheel (12) .
- ✿ Move forward or backward to adjust the cutting height .
- ✿ Release the lever (15) and ensure it engaged in the slot properly

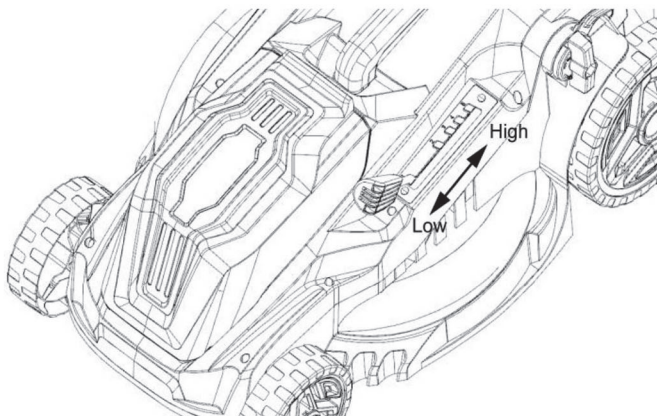

## HANDLE BAR ADJUSTMENT

- ✿ Loosen the angle adjustment wheel (11-a) anti-clockwise but do not remove them .
- ✿ Grasp the grip handle (1) and adjust to a comfortable position for the user.
- ✿ Tighten the angle adjustment wheel (11-a) clockwise afterwards.

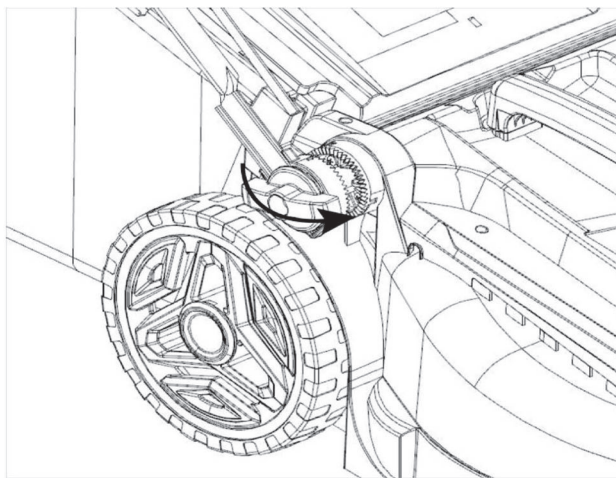

## GRASS INDICATOR

The grass collector is equipped with a hatch that indicates the filling during operation.

- ✿ When the hatch is opened, indicator (7) is blown up by airflow, which means the grass collector has sufficient volume left to collect grass.
- ✿ When the hatch is closed, the grass collector is full and must be emptied.

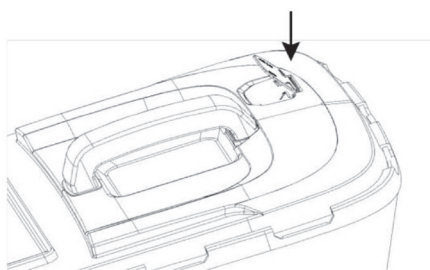

 **Note:** A full grass catcher will reduce the performance of this product.

## EMPTYING

Empty the grass collector frequently during use. Do not wait until it is completely full. We recommend emptying it when it is half full.

A full grass catcher will reduce the performance of this product. Switch the product off and make sure that the motor has stopped and the cutting blade has stopped rotating.

- ✿ Lift the rear flap (10) and lift the grass collector off the hooks
- ✿ Remove the grass clippings from the rear discharge chute into the grass collector. Use a proper tool such as a brush.
- ✿ Remove the grass collector by its carry handle .
- ✿ Empty the grass clippings onto a compost heap.
- ✿ Re-fit the grass collector to the product.

## GENERAL OPERATION

- ✿ Check the product, its battery pack and charger as well as accessories for damage before each use. Do not use the product if it is damaged or shows wear. Take care of any problem you find or have the product checked by qualified specialist.
- ✿ Double check that accessories or attachments are properly fixed.
- ✿ Always push the product using the grip handle (1). Keep the handles dry to ensure safe support.
- ✿ Ensure that the air vents are always unobstructed and clear. Clean them if necessary with a soft brush. Blocked air vents may lead to overheating and damage the product.
- ✿ Switch the product off immediately if you are disturbed while working by other people entering the working area. Always let the product come to complete stop before putting it down.
- ✿ Do not overwork yourself. Take regular breaks to ensure you can concentrate on the work and have full control over the product.

## STARTING/STOPPING

**⚠ WARNING!** Before starting, put the product on a flat surface free of high grass! Clean the underside of the deck! Start the motor carefully according to instructions. Keep your feet well away from the cutting blade !Do not tilt the product when starting the motor.

- ✿ Install the battery pack (22) into the battery compartment .
- ✿ Insert the safety key (20) into the slot fully .
- ✿ Close the battery cover (16) and stand behind the grip handle (1).
- ✿ While holding the safety switch button (3) pressed , pull the start lever (2) towards the grip handle (1) .
- ✿ After the mower starts, release the safety switch button (3).
- ✿ The product begins mowing.
- ✿ Release the start lever (2) to stop the mower.

## 7. TECHNICAL SPECIFICATIONS

<b>General</b>	<b>FZR 70375-0</b>
Rated voltage	2x20V
Rated no load speed n0	2800-3400 min-1
Max. cutting width	38 cm
Cutting height range	30-75 mm, 5 levels
Grass catcher volume	42 l
Wheel size	140 (front) / 178 (rear) mm
Weight	approx. 11.5 kg

### ACCESSORIES

Item number	Accessory
FDUZ 79020	Battery pack 2 Ah
FDUZ 79040	Battery pack 4 Ah
FDUZ 79100	Fast charger
FDUZ 79110	Fast dual charger

## 8. TROUBLESHOOTING

**⚠ DANGER! Risk of injury!** Unprofessional repairs may mean that your unit will no longer operate safely. This endangers you and your environment.

Malfunctions are often caused by minor faults. You can easily remedy most of these yourself. Please consult the following table before contacting the vendor. You will save yourself a lot of trouble and possibly money too.

Error/Fault	Cause	Remedy
Device does not work.	Battery pack discharged?	Charging the battery pack
	Battery pack defective?	Contact your local vendor.
Unit does not switch on.	Did you wait for the delay?	Wait for the switch on delay of 2 seconds.
The mower cuts grass unequally.	The lawn is ragged or bumpy. The mowing height is not set properly.	Check the mowing area. Move the float to a higher position.
Strange noise.	Screws/parts come loose?	Tighten screws.
	Foreign objects in the blades?	Remove foreign objects.
	Blade damaged?	Have blade sharpened, or replace.
Cut result is not sufficient.	Blade is blunt?	Have blade sharpened, or replace.

If you can't fix the fault yourself, contact your nearest vendor. Please be aware that any improper repairs will also invalidate the warranty and additional costs may be incurred.

## 9. MAINTENANCE

**⚠ ATTENTION!** Always switch off the mower and remove the battery before removing the grass catcher.

**📖 Note:** We recommend regularly carrying out the maintenance below, this will increase the lifetime and reliability of the machine.

- ✿ Regularly visually inspect the machine for defects such as a loose blade, blade installed upside down, blade damage or damaged or excessively worn parts.
- ✿ Also regularly check that the protective covers and protective elements are not damaged and are properly placed.
- ✿ Before using the machine, carry out all necessary repairs and maintenance.
- ✿ If, despite regular maintenance, the machine does not work, please contact our customer service, the repair should be carried out by our contractual partner in one of the specialised Fieldmann workshops.

### 9.1 REPLACING THE BLADE

- ✿ For this task, we recommend that you contact an authorised service centre.
- ✿ Always use original spare parts.

**⚠ Important!** Always disconnect the mower from the battery and check that the engine is switched off before inspecting the blades.

**⚠ ATTENTION:** Remember that the blade still rotates several seconds after the motor is turned off. Never attempt to stop the blade. In regular intervals, check that the blade is securely fastened, in good condition and sharp. If necessary, sharpen or replace it.

In the event that the blade hits an object while mowing, turn the lawnmower off and wait until the blade comes to a stop. Then check the condition of the blade and its fastening bolts.

If these are damaged or if they have been lost then they must be replaced without delay.

**⚠ Important!** Use protective gloves when working.

Loosen the bolt holding the blade (using the appropriate wrench) by turning anticlockwise, remove the blade and replace it with a new one. Check that the new blade is installed in the correct direction. Tighten the screw by turning clockwise.

### 9.2 BATTERY CARE

#### Storage after the season

For optimal performance, we recommend that you charge the battery every two months while not in use.

**⚠ ATTENTION:** Fully charge the battery before storing.

**⚠ ATTENTION:** Do not store the battery in places where the temperature drops below 10° C

## 10. DISPOSAL



The machine, rechargeable batteries, accessories and packaging should be sorted for environmentalfriendly recycling.

Do not dispose of power tools and batteries/rechargeable batteries into household waste!

### Only for EC countries:



According to the European Guideline 2012/19/EU, power tools that are no longer usable, and according to the European Guideline 2006/66/EC, defective or used battery packs/batteries, must be collected separately and disposed of in an environmentally correct manner.

### INSTRUCTIONS AND INFORMATION ON DISPOSING OF USED PACKAGING MATERIALS

Put any used package material to the place determined by the municipality for waste disposal.

### DISPOSAL OF USED ELECTRIC AND ELECTRONIC EQUIPMENT



This symbol on products or accompanying documents means that used electric or electronic products must not be put to ordinary municipal waste. Hand over such products to determined collection points for proper disposal, restoration and recycling. Alternatively, in some countries of the European Union or other European countries you can return your products to your local dealer when you buy an equivalent new product. By dutiful disposal of this product you can preserve precious natural resources and you help prevent any potential adverse effects on the environment and human health which could be the results of wrong waste disposal. Ask your local authority or the nearest collection point for additional details. In case of improper disposal of this waste kind penalties can be imposed in accordance with national regulations.

### For companies in the European Union countries

Should you want to dispose of electric and electronic devices, ask your dealer or vendor for necessary information. Disposal in other countries outside the European Union. Should you want to dispose of this product, ask your local authorities or your dealer for necessary information about disposal method.



This product fulfils all basic requirements of the EU directives that apply to it.

Text, design and technical specifications can change without prior notice and we reserve the right for their change.

User manual in the original language.





 **FIELDMANN**<sup>®</sup>  
Home & Garden Performance