



FZR 4006-80BH

English	3 - 18
Čeština.....	19 - 34
Slovenščina.....	35 - 50
Magyarul.....	51 - 66
Polski	67 - 84

Petrol Lawnmower

USER'S MANUAL

Thank you for purchasing this rotary petrol lawnmower. Before you start using it, please, carefully read this user's manual and save it for possible future use.

TABLE OF CONTENTS

1. GENERAL SAFETY INSTRUCTIONS	4
Important safety information	4
Packaging	4
User's Manual	4
2. EXPLANATION OF INSTRUCTION LABELS ON THE MACHINE	5
3. DESCRIPTION OF THE LAWNMOWER	7
4. ASSEMBLY/PREPARATION	7
Taking the lawnmower out of the cardboard packaging	7
5. ASSEMBLING THE LAWNMOWER	8
5.1 Assembling the handle	8
5.2 Installing the wheels and setting the mowing height	8
5.3 Assembling and mounting the grass catcher	9
6. BEFORE STARTING THE LAWNMOWER	9
Adding oil	9
Adding fuel	9
7. CONTROLLING AND OPERATING THE LAWNMOWER	10
Starting the lawnmower	10
Application range for the lawnmower	10
Mowing with the grass catcher	10
Mowing with rear discharge	10
Replacing the mowing blades	11
Changing the motor oil	11
8. SAFETY INSTRUCTIONS	12
General safety instructions	12
Instructions for use	12
9. MAINTENANCE	13
Lawn care	13
Maintenance	13
Servicing	14
Warranty does not cover	14
Storage	15
10. TECHNICAL SPECIFICATIONS	15
11. DECLARATION OF CONFORMITY	16
12. DISPOSAL	17

1. GENERAL SAFETY INSTRUCTIONS

IMPORTANT SAFETY NOTICE

- ✿ Carefully unpack the product and take care not to throw away any part of the packaging before you find all the parts of the product.
- ✿ Store the machine in a dry place out of reach of children.
- ✿ Read all warnings and instructions. Not following warnings or instructions may lead to injury by electrical shock, a fire and/or serious injuries.

PACKAGING

The product is packed in a package that prevents damage during transport. This package is a resource and so can be handed over for recycling.

USER'S MANUAL

Before you start working with the machine, read the following safety and usage instructions.

Acquaint yourself with the operating elements and the correct use of the machine. Keep the user's manual in a safe place where it can be easily retrieved for future use. Save the original packaging, including the internal packing material, warranty card and proof of purchase receipt at least for the duration of the warranty.

If you need to ship this machine, pack it in the original cardboard box to ensure maximum protection during shipping or transport (e.g. when moving or when you need to send this product for repair).

 **Note:** If you hand over the machine to somebody else, do so together with the user's manual. Following the instructions in the included user's manual is a prerequisite for the proper use of the machine. The user's manual also contains operating, maintenance and repair instructions.

The manufacturer takes no responsibility for accidents or damages resulting from not following the instructions in this manual.

2. EXPLANATION OF INSTRUCTION LABELS ON THE MACHINE



Before putting into operation, please carefully read the user's manual.



Keep other persons away from the work area.

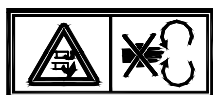

Attention, rotating blades! Protect yourself against the danger of injury to limbs.

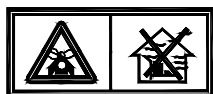

Emission of toxic gasses. Do not use the petrol lawnmower in enclosed or unventilated areas.



Hot surfaces, risk of burns!

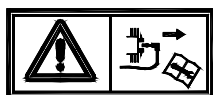

Before carrying out maintenance, turn off the engine and disconnect the spark plug.

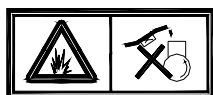

Never add fuel while the engine is running.



Indicates that there is a risk of injury to persons, death or damage to the machine if instructions are not followed



Use hearing protection.
Use eye protection.
Use breathing organ protection.



Always maintain a distance from moving parts.



Travel along the slope on contours, not up and down.



Conforms to all relevant European directives.



Petrol is extremely flammable and therefore allow the engine to cool down for 2 minutes before adding more fuel.

3. DESCRIPTION OF THE LAWNMOWER (Fig. 1)

1. Start / brake lever
2. Handle top part
3. Wing nut screws
4. Handle bottom part
5. Fuel tank cap
6. Fuel primer bulb – Primer
7. Cap with oil dipstick
8. Grass catcher cover
9. Lawnmower starter



Fig. 1

4. ASSEMBLY/PREPARATION

Before assembling and starting the petrol lawnmower, first carefully read the entire user's manual and the instructions contained in it.

⚠ IMPORTANT INFORMATION: The lawnmower is supplied **WITHOUT FUEL AND OIL** in the engine. Your new lawnmower was tested at the production plant meaning that a small amount of residual oil may be in the engine.

TAKING THE LAWNMOWER OUT OF THE CARDBOARD PACKAGING

Take the lawnmower out of the cardboard packaging and check that no loose parts are left in the packaging.

5. ASSEMBLING THE LAWNMOWER

⚠ IMPORTANT INFORMATION: Carefully unfold the lawnmower handle, being careful not to pinch or damage the lawnmower's control cables.

5.1 ASSEMBLING THE HANDLE

1. Insert the bottom part of the handle (Fig. 2 – point 1) into the respective hole on the lawnmower (see arrow) and secure in place with the 2 included screws – one screw with a washer on each side of the handle.
2. Attach the top part of the handle to the bottom part of the handle using the included screws with wing nuts (Fig.2 – point 2).

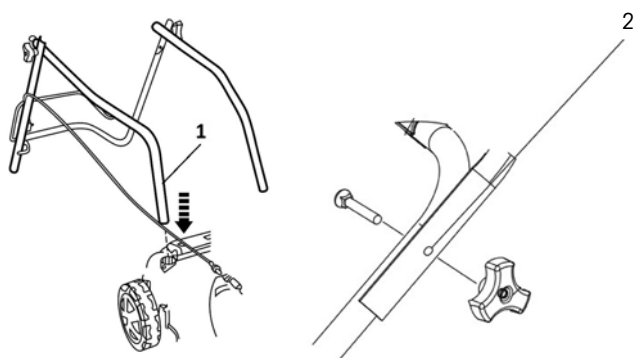

Fig. 2

5.2 INSTALLING THE WHEELS AND SETTING THE MOWING HEIGHT

- ☼ Slide the threaded pin (Fig. 3, point 1) through the wheel
- ☼ Select the required mowing height and screw the wheel into the appropriate hole (Fig 3, point 2+3)
A: 30mm, B: 48mm, C: 66mm
- ☼ Put on the wheel cover (Fig. 3, point 4).
- ☼ Repeat this procedure for all 4 wheels.

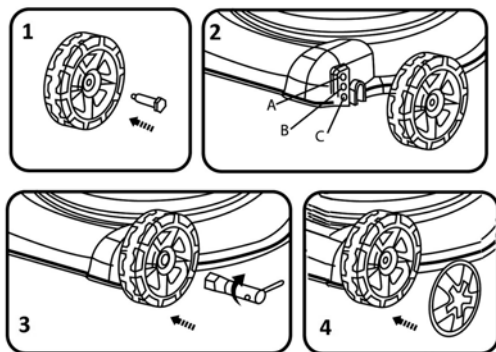

Fig. 3

⚠ ! Attention: The mowing height must be set the same on all wheels.

5.3 ASSEMBLING AND MOUNTING THE GRASS CATCHER

- ✿ attach the textile part of the grass catcher to the metal frame using plastic connectors.
- ✿ before attaching, first lift the rear plastic grass catcher cover
- ✿ using the hooks on the grass catcher, mount it on the lawnmower
- ✿ release the plastic grass catcher cover

6. BEFORE STARTING THE LAWNMOWER

ADDING OIL

The lawnmower is supplied without motor oil. Before first start up, add motor oil SAE30 or 15W-40 (approx 600 ml) according to the following instructions.

1. When pouring in the oil, place the lawnmower on a level surface.
2. Pull the cap with the oil dipstick out of the oil refill hole (Fig.4 – point 1).
3. After adding oil, put the dipstick back into the hole and tighten it.
4. The oil level must be between the upper (MAX) and lower (MIN) limit (Fig.4 – point 1).

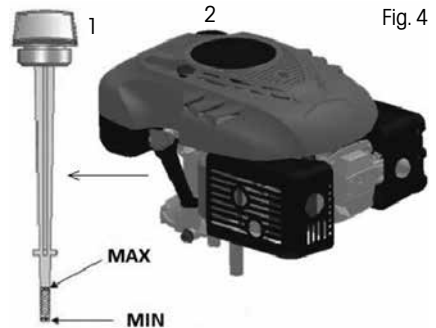

⚠ Caution! DO NOT OVERFILL the oil tank, otherwise a large amount of smoke will come out of the exhaust when the lawnmower is started up.

⚠ IMPORTANT INFORMATION: Check the oil level before every use of the lawnmower. Add oil if necessary. Add oil up to the MAX level mark on the oil dipstick.

⚠ IMPORTANT INFORMATION: Replace the oil after the first 5 hours of operation and subsequently after every 25 hours of operation.

ADDING FUEL

The suitable type of fuel for this engine is NATURAL 95

After unscrewing the fuel tank cap (Fig 4 – point 2), add the fuel, pouring it in all the way up to the collar of the fuel tank but do not overfill it.

Always add fresh, clean and approved lead-free petrol with an octane rating of at least 95.

⚠ Caution! In the event that you spill any oil or fuel on the lawnmower when refilling, wipe it away immediately. Do not store or add fuel or handle it in any way in the vicinity of an open fire.

⚠ Caution! Fuels mixed with alcohol or fuels with ethanol or methane additives may bind moisture to themselves, which may result in separation during storage and the formation of acids. Subsequently during storage the acid vapours may damage the fuel system of the lawnmower engine. These fuels must not be used in the lawnmower.

- ⚠ IMPORTANT INFORMATION:** When not using the lawnmower for longer than 30 days, drain the fuel tank, start the engine and let it run until the fuel lines and the carburettor are empty (the engine will stop on its own). This will prevent future engine problems.
Before using it again, add fresh fuel into the fuel tank. For more information, see chapter Storage instructions.

7. CONTROLLING AND OPERATING THE LAWNMOWER

STARTING THE LAWNMOWER

1. If the engine is not warmed up, press the fuel primer bulb 2-3 times (Fig. 5 – point 1).
If the engine is already warm, it is not necessary to use the fuel primer bulb.
2. Pull the start/brake lever towards the handle and hold it there (Fig. 5 – point 2), then pull on the pull cord (Fig. 5 – point 3). The engine should start up after 3-4 pulls.
3. The engine is turned off by releasing the start/brake lever.

Fig. 5

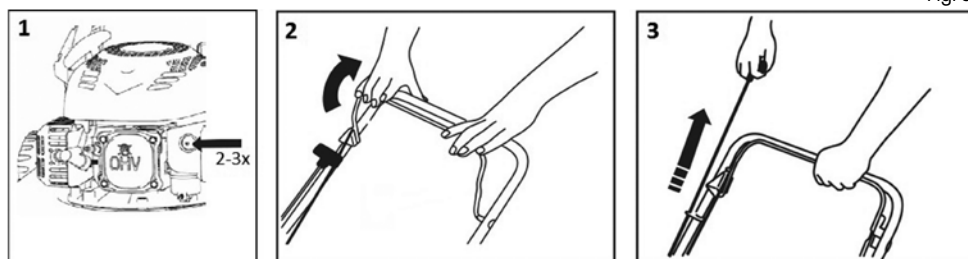

- ⚠ Caution!** A small amount of smoke may be emitted when the engine is started up for the first time as the protective layers in the engine are burnt off. This is completely normal and does not constitute a problem.

APPLICATION RANGE FOR THE PETROL LAWNMOWER

Mowing with collection of grass clippings in a grass catcher
Mowing with rear discharge of grass clippings

MOWING WITH THE GRASS CATCHER

When the grass catcher is installed, grass clippings are discharged into the grass catcher

MOWING WITH REAR DISCHARGE

Without the grass catcher installed, the grass catcher cover serves as a deflector that directs the movement of the grass clippings towards the ground. A row of grass clippings is thereby formed behind the lawnmower

REPLACING THE MOWING BLADES

⚠ Caution! For this task, we recommend that you contact an authorised service centre.

⚠ Caution! Prior to removing the blade, drain the oil from the oil tank.

If you wish to replace the mowing blade, remove the bolt (Fig. 6). Perform the installation according to the provided picture. Tighten the screw. The tightening torque is 40 Nm. When replacing the the blade, replace the fastening bolt also.

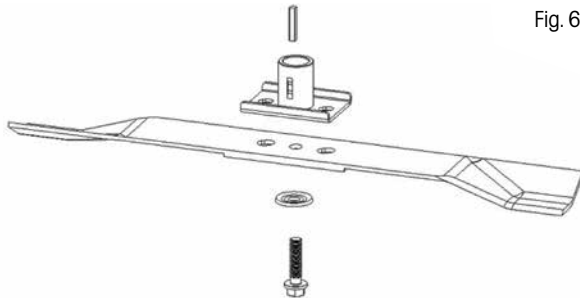

Fig. 6

CHANGING THE MOTOR OIL

⚠ Caution! For this task, we recommend that you contact an authorised service centre.

The drain plug is located under the engine (Fig. 7 – point 1). Place a suitable container for catching the used oil under the engine and remove the plug. Tilt the lawnmower so that all the oil can drain from the oil tank.

Start up the lawnmower engine for a short while to warm up the oil. Then extract the oil with the FZR 9050 oil extractor. Add type SAE30 or 15W-40 oil into the oil tank. When the oil dipstick is inserted into the hole and screwed in, the oil level should be between the Min and Max marks (Fig. 7). Do not overfill the oil tank. Start the engine and allow it to run for a short time. Stop the engine, wait 1 minute and remeasure the oil level in the tank. Add oil to the required level if necessary.

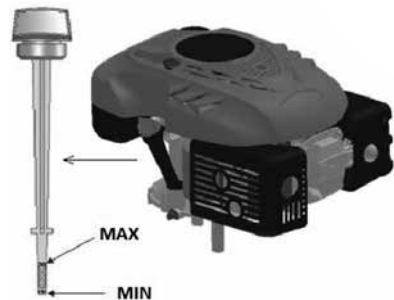

Fig. 7

8. SAFETY INSTRUCTIONS

GENERAL SAFETY INSTRUCTIONS

- ✿ This product is used exclusively for mowing grass. Do not use it for any other purposes than those intended. Otherwise there is a risk of damaging it or an injury.
- ✿ Never allow children or persons who are not acquainted with the contents of this user's manual to work with the machine.
- ✿ The person operating the lawnmower is responsible for the safety of persons in the work area. Never operate the lawnmower in the near vicinity of other people, children or freely roaming animals.
- ✿ Before starting mowing, check the terrain where the lawnmower will be used and remove stones, wires, sticks, splinters, bones and other foreign objects, which could become caught in it or deflected or cause injuries.

INSTRUCTIONS FOR USE

- ✿ All nuts, pins and bolts must be properly tightened so that the machine is in a safe and operational condition.
- ✿ Never use the lawnmower without the grass catcher or protective cover.
- ✿ Never use the lawnmower with loose mowing blades. Always check in advance that all respective bolts are securely tightened. Blunt blades must be sharpened evenly. Damaged blades must be replaced.
- ✿ When working with the lawnmower, wear long pants and solid footwear.
- ✿ Never start the lawnmower in enclosed or poorly ventilated areas where fumes could accumulate. Emissions from the engine contain carbon monoxide, which is life threatening.
- ✿ Work only during sufficient light conditions (in daylight or sufficient artificial lighting).
- ✿ Do not use the lawnmower when it is raining or if the grass is wet.
- ✿ Proceed especially carefully when mowing in elevated terrain (on a slope). Always mow perpendicular to the slope, parallel to the contour, and not directly up/down.
- ✿ Under no condition leave the lawnmower running without supervision; if you leave the lawnmower, turn off the engine.
- ✿ Never lift the rear part of the lawnmower when starting it and always keep your limbs away from the cutting deck or the rear grass ejection chute while the engine is running.
- ✿ Never modify the engine's speed setting.
- ✿ On lawnmowers with travel, release the travel lever before starting the engine.
- ✿ Never transport the lawnmower while its engine is running.
- ✿ Stop the engine and disconnect the spark plug in the following cases:
 - when performing any task whatsoever under the mowing deck or in the rear grass ejection chute.
 - when performing maintenance, repairs or inspecting the machine.
 - before carrying, lifting or transporting the lawnmower.
 - when you leave the lawnmower without supervision or you are getting ready to adjust the mowing height.
 - before removing and emptying the grass catcher.
 - when an impact with a foreign object occurs, stop the engine and carefully inspect to ensure that there is no damage. In the event of damage, take the lawnmower to a specialised service centre for repairs.

⚠ ATTENTION: The mowing blade continues to rotate for several seconds after the engine is turned off.

- if the lawnmower is vibrating abnormally (immediately identify and remedy the cause of the vibration).
- For the purpose of ensuring safe operation, regularly check that the pins, bolts and nuts on the lawnmower are securely tightened.

⚠ ATTENTION: FUEL IS A VERY FLAMMABLE LIQUID.

- ☼ Store fuel in a suitable container.
- ☼ Only add fuel in an open and well ventilated location. When handling fuel, do not smoke or use a mobile phone.
- ☼ Only add fuel when the engine is turned off. Never open the fuel tank or add fuel if the engine is hot or if it is running.
- ☼ If fuel is spilled, do not start the engine. Take the lawnmower away from the location where the fuel was spilled and take care to avoid possible ignition. Continue with work only after the spilled fuel has evaporated and the fuel fumes have dissipated;
- ☼ After adding fuel, securely tighten the fuel tank cap and the cap on the fuel canister.

⚠ ATTENTION: Before carrying out maintenance or repairs, stop the engine and disconnect the spark plug.

9. MAINTENANCE

LAWN CARE

- ☼ Various forms of care are required depending on the type of grass area.
- ☼ Therefore, always read the instructions included on seed packages with respect to the mowing height for the growing conditions in the given locality.
- ☼ It is necessary to always keep in mind that the larger part of grass consists of a stem and one or more leaves. When the leaves are cut off completely, the lawn is damaged and the renewal of growth will be much more difficult.
- ☼ The following instructions generally apply:
 - excessively low mowing causes disruption to the roots and subsequently "spotty" appearance;
 - in summer, mowing must be higher to prevent the soil from drying out;
 - mowing wet grass may result in a lower efficiency of the blade due to grass catching on the blade and grass being ripped out of the ground;
 - in the event of exceptionally tall grass it is appropriate to perform the first mow at the maximum permitted mowing height of the machine and then mow again only after two or three days.
- ☼ The lawn will have a better appearance when it is mowed regularly over its entire area at the same height with alternating mowing directions.

MAINTENANCE

- ☼ All nuts, pins and bolts must be properly tightened so that the machine is in a safe and operational condition. Regular maintenance is the basic prerequisite for ensuring safety of the user, maintain the lawnmower's operating condition and high performance.
- ☼ Never store a machine with petrol in the fuel tank inside a building where the fumes could come within range of an open fire, sparks or sources of high temperature
- ☼ Before storing in any enclosed area, allow the engine to cool down.

- ✿ To reduce the risk of a fire, ensure that the lawnmower and in particular the engine, exhaust muffler, battery and also the location of spare fuel storage are free of grass, leaves or excessive amounts of lubricant.
- ✿ Regularly inspect the condition of the deflector and the grass catcher; replace if damaged.
- ✿ Drain the fuel in a well ventilated area when the engine has cooled down.
- ✿ When removing or installing the mowing blade, use thick work gloves.
- ✿ It is necessary to check the balance of the mowing blade every time that it is sharpened.

⚠ ATTENTION: Before carrying out maintenance or repairs, stop the engine and disconnect the spark plug.

- ✿ Regularly inspect the lawnmower and ensure that all grass deposits are removed from the underside of the chassis.
- ✿ Regularly lubricate the axle of the chassis and the bearings using a suitable lubricant.
- ✿ Regularly inspect the condition of the blades because they have a significant effect on the performance of the lawnmower. Blades should always be sharp and balanced.
- ✿ In regular intervals, check that all nuts and bolts are tightened. Nuts and bolts that are worn out or incorrectly tightened may cause serious damage to the engine or the frame.
- ✿ If the blade strongly impacts an obstacle, stop the lawnmower and take it to an authorised service centre.
- ✿ **BLADE:** the blade is made from pressed steel. To achieve the best possible mowing results, regularly sharpen the blades, approximately after every 25 hours of operation. Check that the blade is always correctly balanced. To do this, insert a steel axle (with a diameter of 2-3 mm) into the middle hole. If it is correctly levelled, the axis will remain in the horizontal position.
- ✿ If the blade does not remain in the horizontal position, replace it.
- ✿ When removing the blade, screw out the bolt, check the load bearing part of the blade. If the parts are worn out or damaged, replace them.

⚠ ATTENTION: Always use only original spare parts. Poor quality spare parts may cause serious damage to the lawnmower and create a safety hazard.

SERVICE

- ✿ In the event that after purchasing the product you find any kind of defect, contact the service department. When using the product, follow the instructions contained in the included user's manual.
- ✿ A complaint will not be accepted if you modified the product or if you did not follow the instructions in the user's manual.

WARRANTY DOES NOT COVER

- ✿ Normal wear and tear of operating parts of the machine as a result of its use
- ✿ Servicing tasks related to standard maintenance of the machine (e.g. cleaning, lubrication, tuning, etc.). Defects caused by external effects (e.g. climatic conditions, dustiness, inappropriate use, etc.)
- ✿ Mechanical damage resulting from the machine being dropped, impact, etc.
- ✿ Damages resulting from unprofessional handling, overloading, use of incorrect parts, inappropriate tools, etc.
- ✿ On returned products that were not properly protected against mechanical damage during transport, the risk of potential damage is borne exclusively by the owner.

STORAGE

- ✿ If you will not be using the machine for an extended period of time, store it according to the following instructions. This will extend the lifetime of the machine.
- ✿ Fully drain fuel from the fuel tank and the carburettor.
- ✿ Screw out the spark plug and pour a small amount of motor oil into the socket. Gently pull the pull cord 2 to 3 times.
- ✿ Use a clean cloth to clean the exterior surfaces. Store the machine in a clean dry location.

10. TECHNICAL SPECIFICATIONS

Engine	RATO RV 80-S
Engine type	OHV, air cooled, 4-stroke
Rated power	1.6 kW
Engine rpm	3000 rpm
Displacement	79,7 cm ³
Starting	Pull cord
Fuel tank volume	0.6 litres
Recommended fuel	Petrol - lead-free, at least 95 octane
Oil tank volume	0.4 l
Recommended oil	SAE30, 15W-40
Mowing height adjustment	3 positions, each wheel independently
Adjustable mowing height range	30/48/66 mm
Mowing coverage	390 mm
Wheel size	Front 155 mm, rear 155 mm
Grass catcher capacity	40 l
Chassis	plastic
Declared noise level	96 dB (A)
Maximum vibration level	5,2 m/s (K=2,1)
Weight	14.5 kg

Amendments to text and technical parameters are reserved.

Changes in the text, design and technical specifications may be made without prior notice and we reserve the right to make such changes.

11. DECLARATION OF CONFORMITY



FAST ČR, a.s.
U Sanitasy 1621, 251 01 Říčany, Czech Republic
tel.: +420 323 204 111, fax: +420 323 204 110

EU DECLARATION OF CONFORMITY

Product / brand: Gasoline Powered Lawn Mower / **FIELDMANN**

Type / model: **FZR 4006-80BH** as factory model RMP39Q-V80
Engine 79,7cm³; 1,6kW; speed 3000 rpm; cutting width 390 mm
L_{pA} = 74,3 dB(A); L_{WA} = 96 dB(A)

Manufacturer: FAST ČR, a.s.
U Sanitasy 1621, 251 01 Říčany, Czech Republic
VAT no: CZ24777749

**This declaration of conformity is issued under the sole responsibility of the manufacturer.
Person in charge of completing the technical documentation: FAST ČR, a.s.**

The object of the declaration described above is in conformity with the relevant Union harmonization legislation:

Directive MD 2006/42/EC	Directive EMC 2014/30/EU
Directive NEOE 2000/14/EC	Directive RoHS 2011/65/EU+(EU)2015/863
Directive Emission of gaseous 2016/1628/EU	

The relevant harmonized standards and the other technical specifications:

EN ISO 5395-1:2013+A1	EN ISO 14982:2009
EN ISO 5395-2:2013+A1+A2	
EN ISO 12100:2010	



Place of issuance: Prague
Date of issuance: 22. 08. 2023

Name: Petr Uher - Responsible Person
Signature:



FAST ČR, a.s.
U Sanitasy 1621, 251 01 Říčany
tel.: +420 323 204 111
ICO: 247 77 249, DIČ: CZ 247 77 749

12. DISPOSAL

INSTRUCTIONS AND INFORMATION REGARDING THE DISPOSAL OF USED PACKAGING MATERIALS

Dispose of used packaging material at a site designated for waste in your municipality.



The machine and its accessories are manufactured from various materials, e.g. metal and plastic.

Take damaged parts to a recycling centre. Inquire at the relevant government department.



This product meets all the basic requirements of EU directives that apply to it.

Changes in the text, design and technical specifications may be made without prior notice and we reserve the right to make these changes.

User's manual in the original language.

