

FZG 1018

Checklist before starting

- Read these instructions carefully
- Carefully dispose of all plastic bags and keep them out of the reach of children.
- Please read the "Safety" section of this instruction booklet on the safety precautions to take before using your charcoal barbecue.
- Check the components and ensure that you have all the parts listed. If not, contact your local shop, which will be able to help you
- Take a moment to familiarise yourself with the content and before beginning assembly, check that all of the holes are clean and that there is no paint residue in them.
- When you are ready to start assembly, ensure that you have lots of space and that the area is clean.

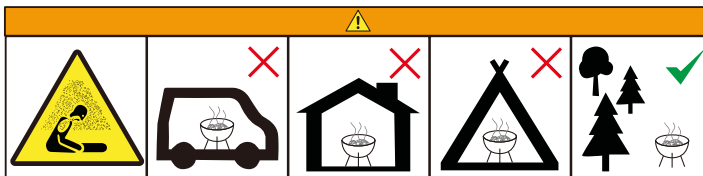

Do not use the barbecue in a confined and/or habitable space e.g. houses, tents, caravans, motor homes, boats. Danger of carbon monoxide poisoning fatality.

Take note of all of the following instructions:

1. The barbecue must be installed on a horizontal and stable surface before use.
2. The barbecue must be hot and the charcoal must remain lit for at least 30 minutes before beginning to cook the food. When the charcoal forms a grey layer of ash, you can start to cook.
3. Before starting to cook, wait until a layer of ash covers the charcoal.
4. **WARNING!** This barbecue will become very hot, do not move it during operation!
5. **WARNING!** Do not use this barbecue indoors!
6. Do not use spirit or petrol for lighting or re-lighting! Use only firelighters complying to EN 1860-3!

7. **WARNING!** Keep children and pets away from this barbecue.
8. This barbecue complies with the regulations in force.
9. However, using it requires a minimum amount of monitoring and precautions.
10. In particular, do not use alcohol, petrol or any other flammable liquid to light or rekindle the fire, and do not let children near the burner.
11. Regrettably, a large number of accidents occur each year. The resulting burns are particularly serious in children: because of their size, their faces are more often than not at the same height as the burner.
12. Do not increase the flames in a charcoal barbecue using a fire lighting product or any other flammable product. Regularly clean the cooking grills.
13. To avoid ingesting significant amounts of benzopyrene (a decomposition product from carcinogenic fats), keep the barbecue grill as far as possible from the heat source, or opt for an upright cooking model.
14. Fuel to use: charcoal.
15. Maximum quantity to be used: 1.2 kg

Precautions:

16. Use potholders, gloves or a utensil to adjust or move a part of the barbecue (for example, the air control lid or the handle, ash tray or non-adjustable cooking grill) during use.
17. Use protective gloves to assemble the barbecue.

Technical specifications	
Grill size	138 x 58 x 118 cm
Grilling surface	66 x 42 cm
Grilling surface height	80 cm
Chrome cooking grid	✓
Stacking area	✓
Cover / lid	74 x 46 x 21 cm
Thermometer	✓
Weight	33,5 kg









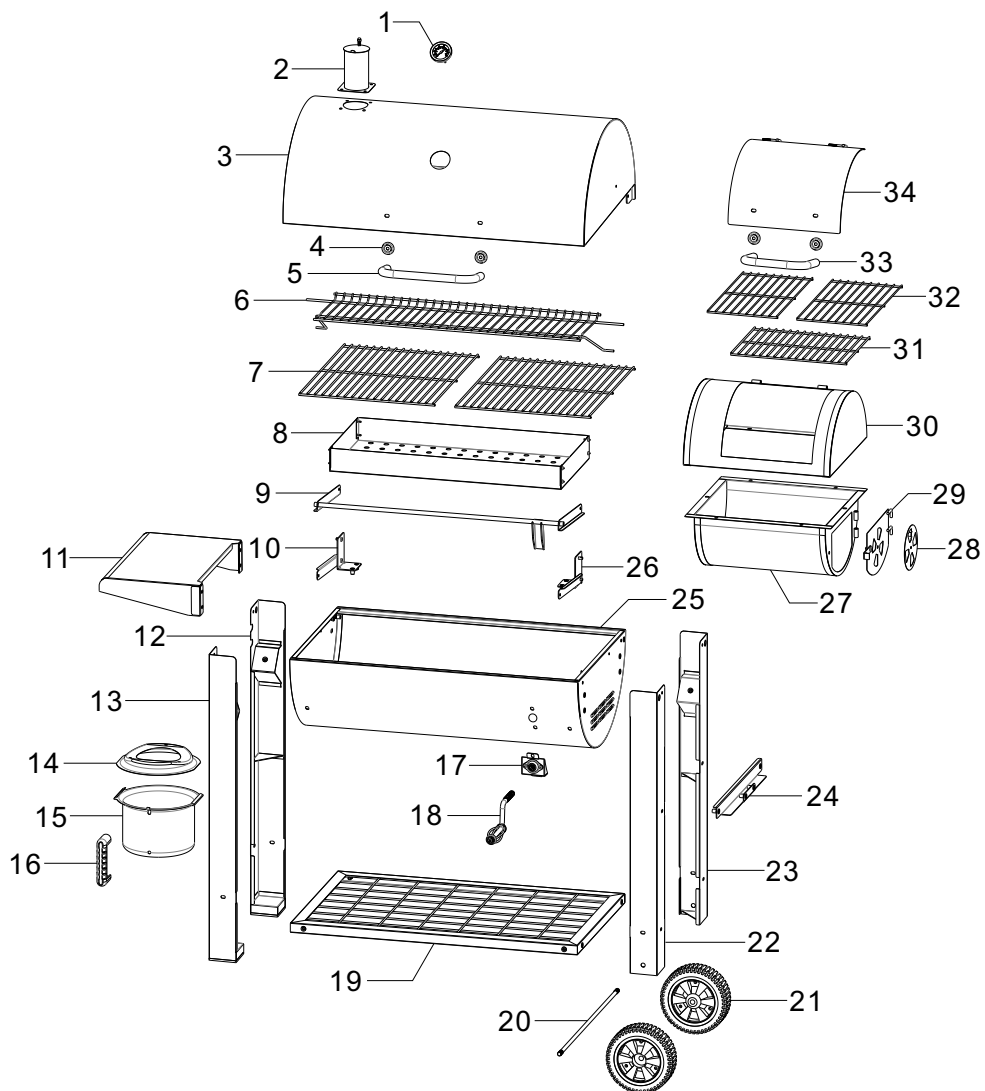



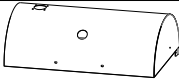



Any change in the text and specification reserved.



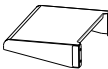

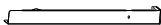







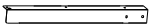
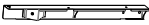

The user's manual is in the languages version.



Changes in text, design and technical specifications may vary without prior notification and

We reserve the right of their change.



1		x1
2		x1
3		x1
4		x4
5		x1
6		x1
7		x2
8		x1
9		x1
10		x1
11		x1
12		x1
13		x1
14		x1
15		x1
16		x1

17		x1
18		x1
19		x1
20		x1
21		x2
22		x1
23		x1
24		x1
25		x1
26		x1
27		x1
28		x1
29		x1
30		x1
31		x1
32		x2

33		x1
34		x1

A	M6x25 	x4
B	M6x20 	x3
C	M6x12 	x48
D	M5x12 	x4
E	M10 	x2
F	M6 	x12
G	M5 	x4
H	Ø6x16 	x18
I	Ø1.2x20 	x4
J	M6 	x2

1

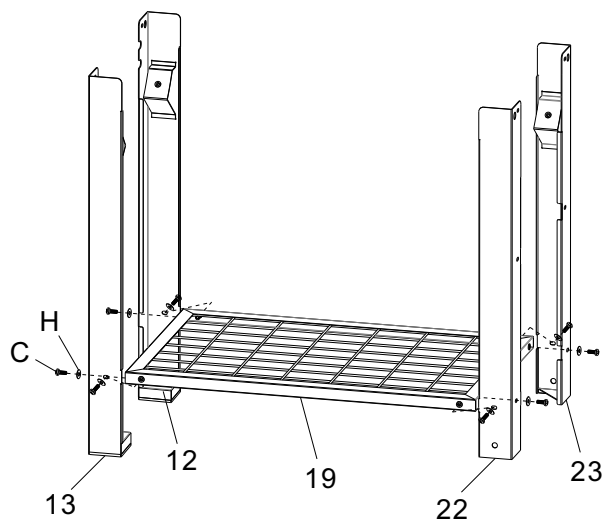

2

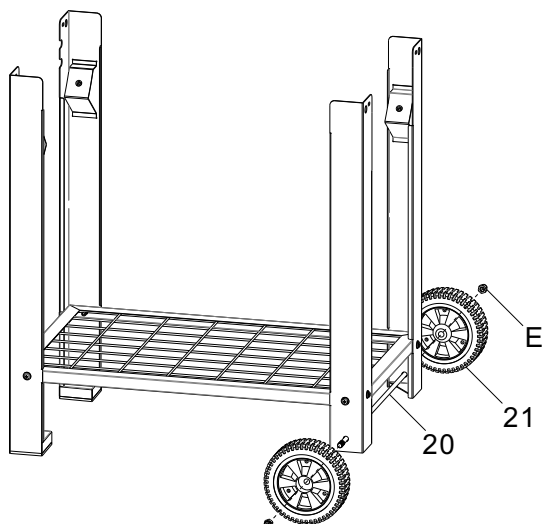

3

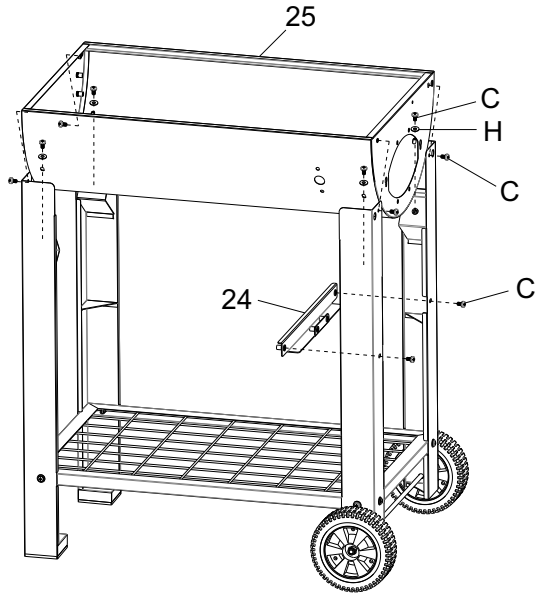

4

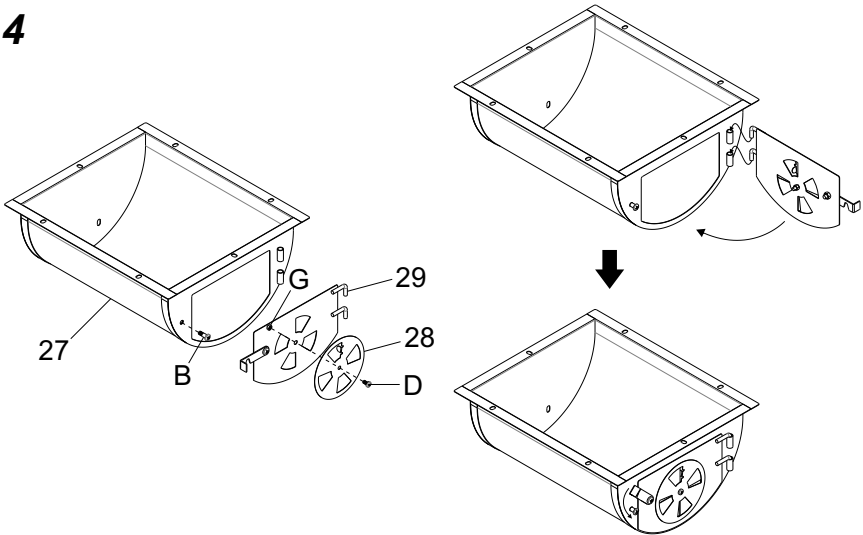

5

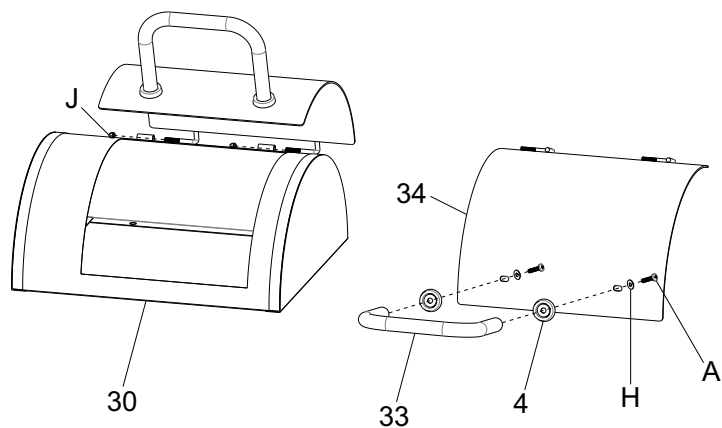

6

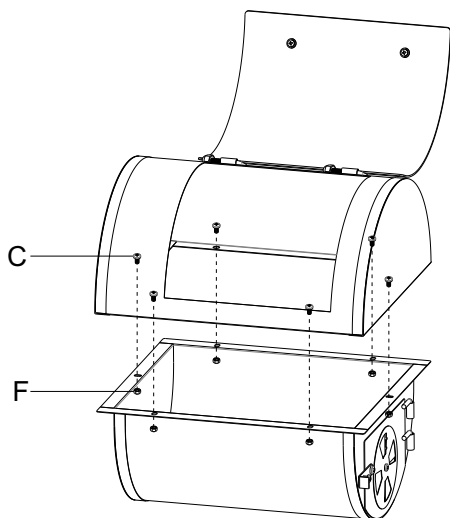

Please install and fix the ONE SIDE (Front) two holes to match the lid and fire bowl , then adjust the OTHER SIDE(Back) of the up and down hole position

7

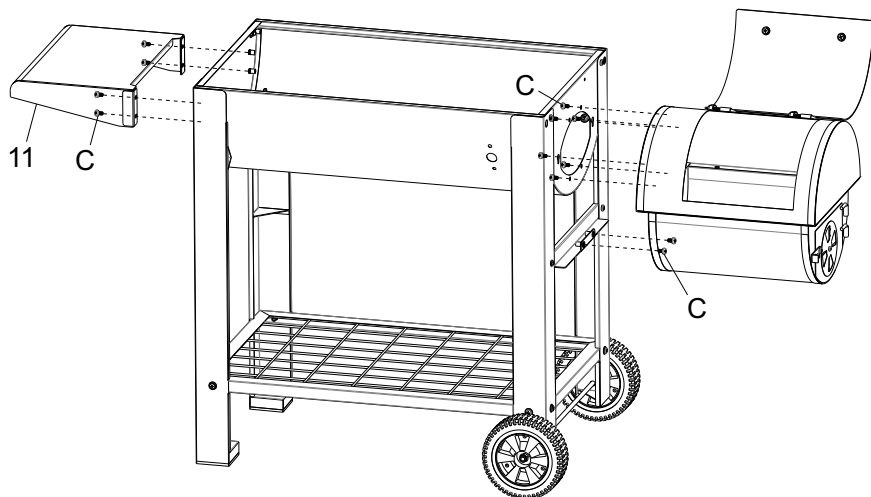

8

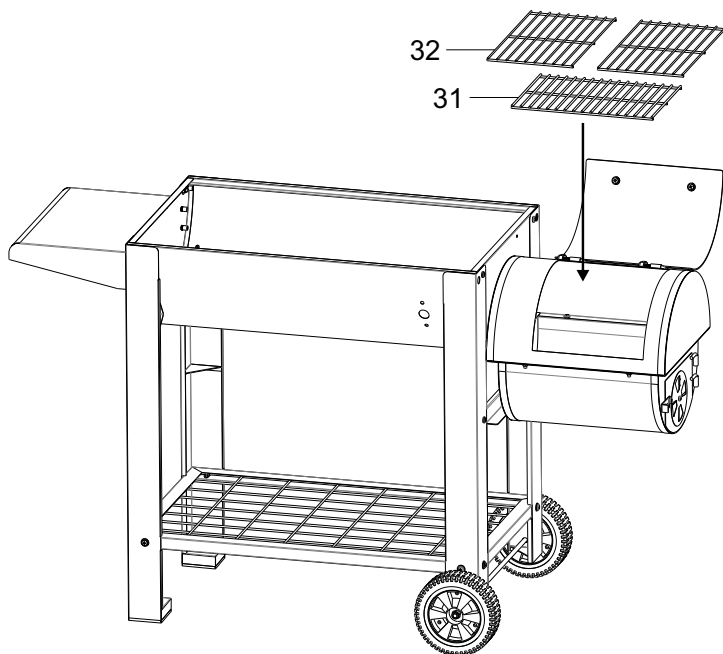

9

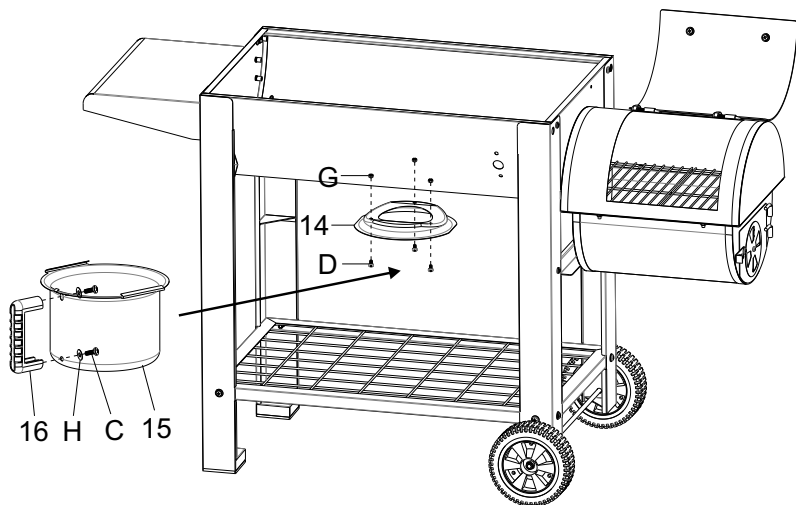

10

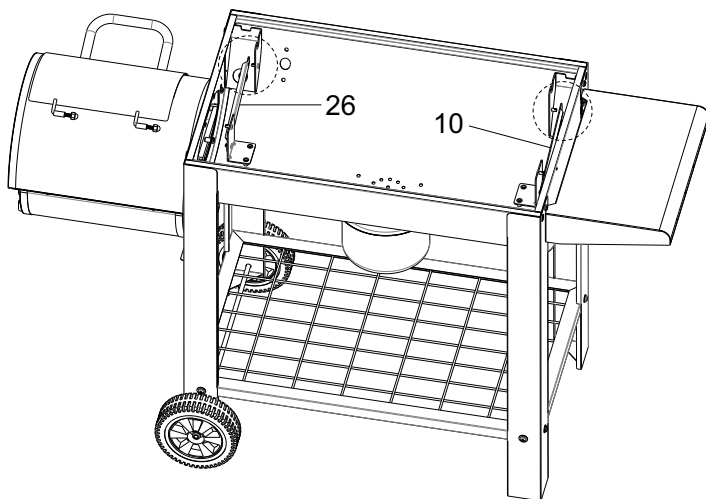
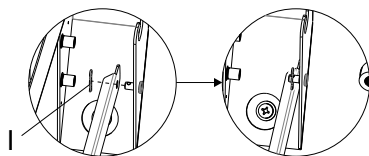

11

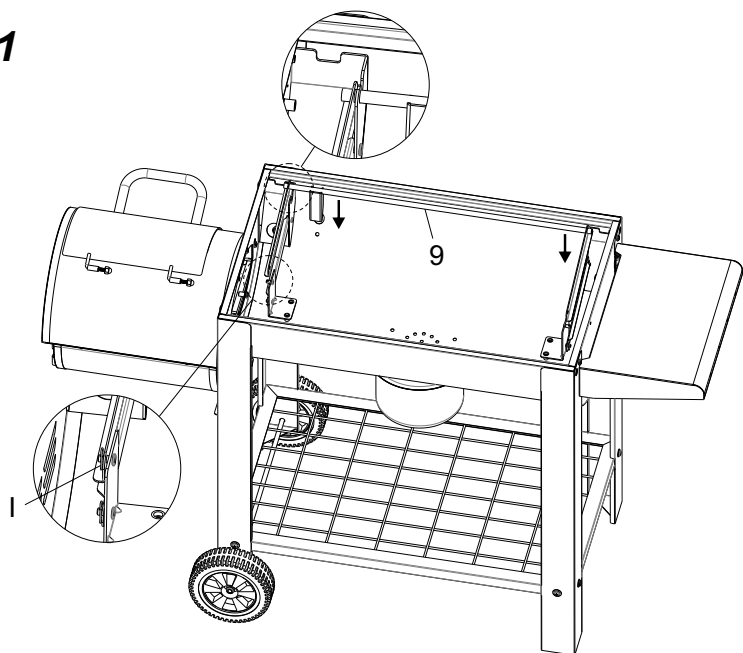

12

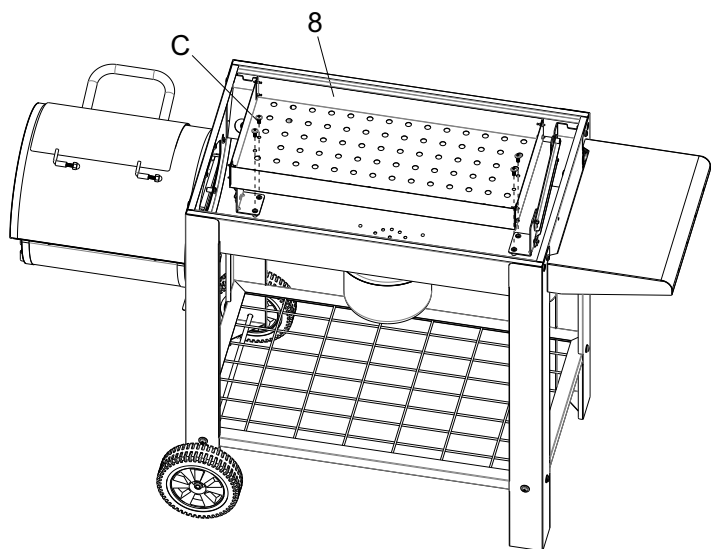

13

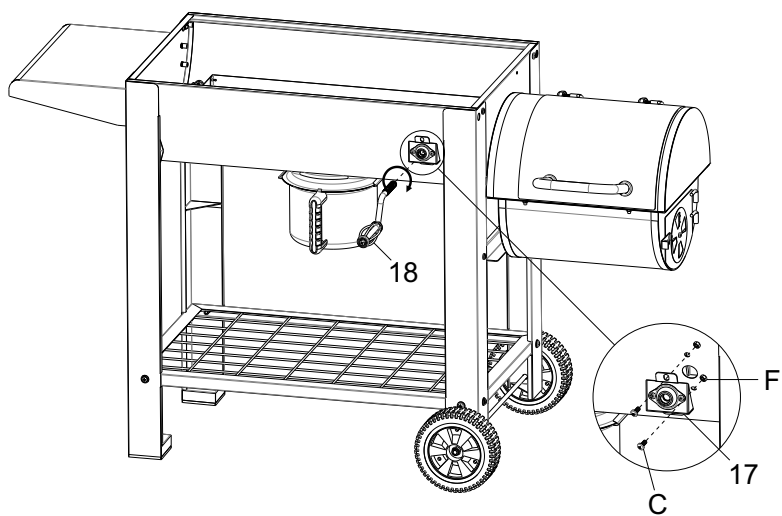

14

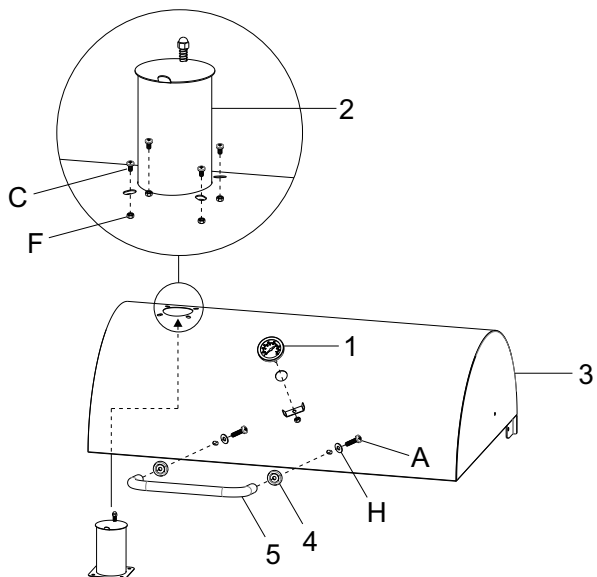

15

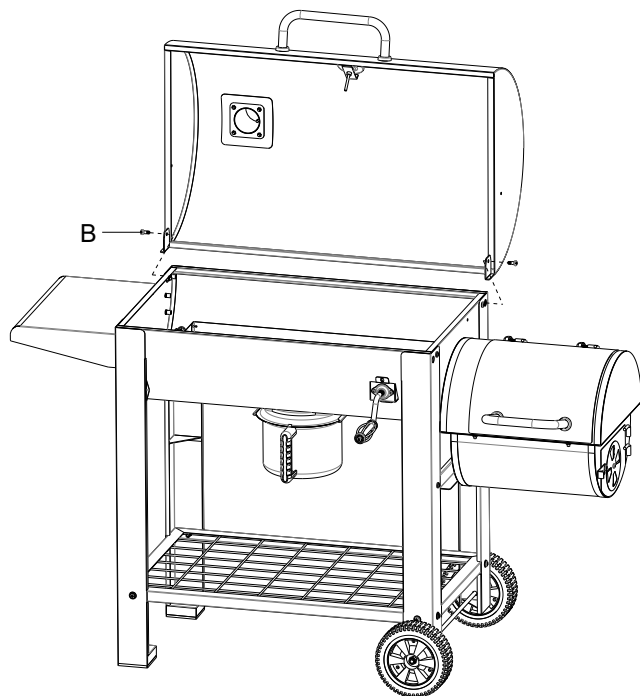

16

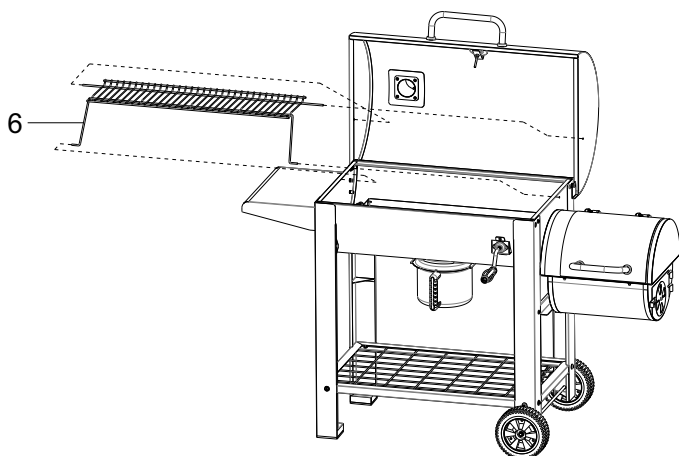

17

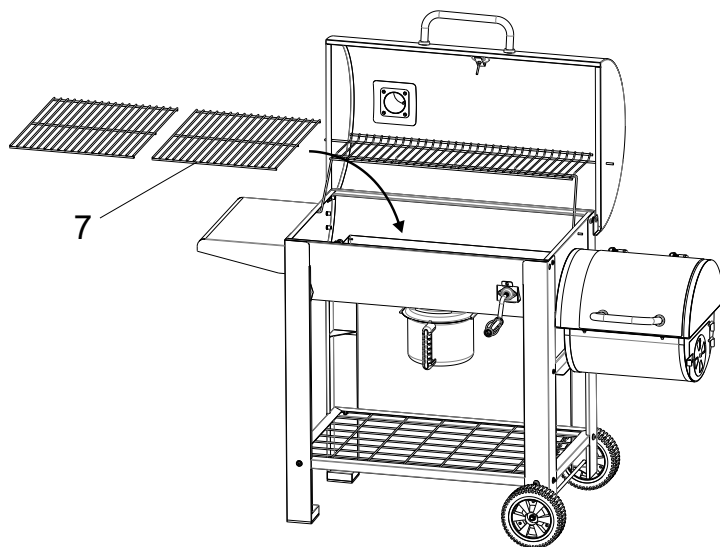

18

