



FIELDMANN®
Home & Garden Performance



FZP 25410-B

English	3-30
Čeština.....	31-58
Slovenčina	59-86
Magyarul	87-114
Polski	115-142

Chain saw

USER'S MANUAL

Thank you for purchasing this chain saw. Before you start using it, please, carefully read this user's manual and save it for possible future use.

CONTENTS

1. GENERAL SAFETY INSTRUCTIONS	5
Important safety notice	5
Packaging	5
User's manual.....	5
2. EXPLANATION OF INSTRUCTION LABELS ON THE MACHINE	6
3. SAFETY INSTRUCTIONS.....	7
Before using the power tool	7
Safety of the operator, work equipment and clothing	7
Instructions for handling fuel.....	9
4. INSTALLING GUIDE BAR AND SAW CHAIN	10
5. OPERATING THE ENGINE	12
STARTING THE ENGINE	12
CHECKING THE OIL SUPPLY	13
ADJUSTING THE CARBURETOR	13
6. FILLING THE OIL TANK AND FUEL TANK	14
TO FILL THE OIL TANK	14
TO FILL THE FUEL TANK	14
7. OPERATION	16
STARTING THE ENGINE	16
TO STOP THE ENGINE.....	16
CHAIN BRAKE.....	16
RELEASE OF THE CHAIN BRAKE.....	17
CHECKING THE LUBRICATION OF THE CHAIN	17
RELEASE OF A JAMMED SAW	17
CUTTING WORK	17
FELLING OF TREES.....	17
8. ADJUSTING THE CHAIN TENSION.....	19
9. CUTTING	19
Safety brake (protection against kickback)	19
Felling trees.....	20
Cutting logs	20
Log lying on the ground.....	20
Log above the ground.....	21
Removing a fallen tree	21

10. CLEANING AND MAINTENANCE	21
Maintenance after every use	21
Cleaning the body of the chain saw.....	21
Maintaining the guide bar	22
Normal maintenance of the guide bar	22
11. SHARPENING THE SAW CHAIN	23
Equipment necessary for sharpening a saw chain.....	23
Sharpening the teeth on the chain	23
Filing the depth gauge.....	24
12. REPLACING THE SAW CHAIN.....	25
13. MAINTENANCE TABLE	26
14. TROUBLESHOOTING	27
15. TECHNICAL PARAMETERS.....	28
Power unit.....	28
16. DISPOSAL.....	29
17. DECLARATION OF CONFORMITY	30

1. GENERAL SAFETY INSTRUCTIONS

Important safety notice

- ✿ Carefully unpack the product and take care not to throw away any part of the packaging before you find all the parts of the product.
- ✿ Store the product in a dry place out of reach of children.
- ✿ Read all warnings and instructions. Not following warnings or instructions may lead to injury by electrical shock, a fire and/or serious injuries.

Packaging

The product is packed in a package that prevents damage during transport. This package is a resource and so can be handed over for recycling.

User's manual

Before you start working with the machine, read the following safety and usage instructions. Acquaint yourself with the operating elements and the correct use of the machine. Keep the user's manual in a safe place where it can be easily retrieved for future use. Save the original packaging, including the internal packing material, warranty card and proof of purchase receipt at least for the duration of the warranty.

If you need to ship this machine, pack it in the original cardboard box to ensure maximum protection during shipping or transport (e.g. when moving or when you need to send this product for repair).

-  **NOTE:** If you hand over the power tool to somebody else, do so together with this user's manual. Following the instructions in the included user's manual is a prerequisite for the proper use of the power tool. The user's manual also contains operating, maintenance and repair instructions.

The manufacturer takes no responsibility for accidents or damages resulting from not following the instructions in this manual.

This chainsaw is not designed for professional use.

2. EXPLANATION OF INSTRUCTION LABELS ON THE MACHINE



Before using the power tool, carefully read the user's manual.



When operating the power tool, wear protective aids such as safety glasses, earmuffs, etc.



Always use two hands when operating the chain saw.



While working use protective gloves.



Use solid insulating work footwear.



Attention! Danger of kickback



Warning! Attention!

3. SAFETY INSTRUCTIONS

⚠ ATTENTION! The safety instructions in this user's manual are marked with the symbol containing critical points, which one needs to pay attention to when operating the power tool to prevent serious or fatal injuries. Please carefully study the instructions and adhere to them.

⚠ ATTENTION! This symbol indicates instructions that must be adhered to in order to prevent accidents that could result in serious or fatal injuries.

📖 NOTE: This symbol indicates a tip or instructions useful when operating the power tool.

Before using the power tool

- 🌸 Before using the power tool, carefully read the user's manual.
- 🌸 Do not use the power tool if you are under the influence of alcohol or narcotics, if you are tired or exhausted. Do not use the power tool if you are taking medication, which could affect or limit your decision-making abilities for safe operation of the power tool.
- 🌸 Do not use the power tool indoors, the emitted gases contain damaging carbon monoxide.
- 🌸 Never use the power tool under the conditions listed below:
 - If the work surface is slippery or if weather conditions do not permit you to maintain a stable stance while operating the power tool.
 - If it is dark, heavy fog or under poor weather conditions, which limit visibility of the work area.
 - During rain, during a storm or in strong winds or under conditions that could be dangerous when operating the power tool.
- 🌸 If you are using the chain saw for the first time, please consult with an experienced user before starting work.
- 🌸 Tiredness or physical exhaustion may lead to inattentiveness, which may result in serious injury
- 🌸 Limit the operating time of the power tool to approx. 10 minutes per single use and try to rest for approximately 10-20 minutes between work sessions. Limit the total amount of work per day to approximately 2 hours.
- 🌸 Make sure that you have the user's manual at hand in case you need to use it.
- 🌸 If you sell, loan or handover the power tool, make sure that you include the user's manual.
- 🌸 Never allow children or other persons that are insufficiently acquainted with the user's manual to use this power tool.

Safety of the operator, work equipment and clothing

- 🌸 When operating a chain saw, you should wear the following work clothing and protective aids:
 - Helmet
 - Safety glasses or protective face shield
 - Work gloves
 - Anti-slip work boots
 - Earmuffs

- ✿ Furthermore, you should also have
 - The included tools
 - Sufficient supply of fuel and chain lubricating oil
 - Accessories for designating the work area (rope, warning signs)
 - Whistle (to call for help)
 - Hand saw or axe (to remove potential obstacles)
- ✿ When working, never wear loose clothing, jewellery, that could become caught by the chain saw. Do not wear sandals when working, do not work barefoot.
- ✿ Check the work area, the item being cut and the cutting direction. Remove obstacles.
- ✿ Never commence work if the work area is not cleared, if you do not have a stable stance and if you do not have a planned escape route in the event of a falling tree.
- ✿ Pay increased attention and keep passers-by and pets away from the work area at a distance of at least 2.5 times the length of the item being cut.
- ✿ Check for damaged, worn out or missing parts of the power tool. Never use the power tool if it is damaged, incorrectly adjusted or incomplete. Check that the chain stops turning when the throttle trigger is released.
- ✿ Keep the handles dry, clean and free of oil and fuel stains.
- ✿ Do not touch the muffler, spark plugs or other metal parts of the engine when the power tool is running or immediately after it is turned off - there is a risk of burns or injury by electrical shock.
- ✿ Pay exceptional attention when cutting thin branches or trunks because fragile material may become caught in the chain and flung towards the operator and may thus cause a loss of balance.
- ✿ When cutting tensioned branches keep in mind that they will fling out when the wood fibres are cut and the tension is released.
- ✿ Check for and remove dry branches that could come loose from the falling tree.
- ✿ Make sure that the power tool is turned off when you put it down.

⚠ CAUTION danger of kickback! Kickback may occur when the nose of the guide bar comes into contact with an item or if the material being cut clamps the chain in the cut. During contact with the item, the chain saw may be flung with the guide bar moving up and back towards the operator. A clamped chain may result in a fast backward movement of the guide bar towards the operator. Both these reactions may lead to a loss of control over the chain saw and subsequent serious injuries. Do not rely only on the chain saw's safety features. As the operator of the chain saw, you must constantly adhere to multiple rules to avoid injuries or damages.

- ✿ If you are acquainted with the kickback principle, you can reduce or eliminate the moment of surprise. Unexpected reactions result in accidents.
- ✿ If the engine is running, hold the chain saw with both hands with the right hand on the rear handle and the left hand on the front handle. Firmly grasp the handle with the thumb going around towards the fingers. A firm grip helps limit kickback and to keep the chain saw under control.
- ✿ There must be no obstacles in the work area. When working with the chain saw, the loose end of the guide bar must not touch a branch, trunk or another obstacle.
- ✿ Cut with the engine running at high speed.
- ✿ A stable stance must be maintained at all times when cutting, do not cut above shoulder height.
- ✿ Adhere to the instructions of the manufacturer for lubricating and sharpening the chain.
- ✿ Only use spare chains and guide bars specified by the manufacturer or their equivalents.

Instructions for handling fuel

The engine of the power tool is designed to use a highly flammable fuel mix. Never store fuel containers or refill fuel in the vicinity of an open flame, wood stove, electrical lines, welding work or other sources of heat or flame, which could lead to ignition.

- ☸ Smoking is forbidden when operating the power tool and when refilling fuel.
- ☸ When refilling fuel, make sure that the power tool is off and that there is no open flame in the vicinity.
- ☸ If the power tool is sprayed with fuel, use a dry cloth to wipe away the stains.
- ☸ After refilling fuel, screw on the fuel tank cap and take the power tool at least 3 m away from the place where it was refilled and then start it up.



Value of sound emission according to European Directive 2000/14/EC



Setting the chain tension



Fuel filler (on fuel tank cap)



oil filler (on oil tank cap)



Choke knob

4. INSTALLING GUIDE BAR AND SAW CHAIN

A standard saw unit package contains the items as illustrated.

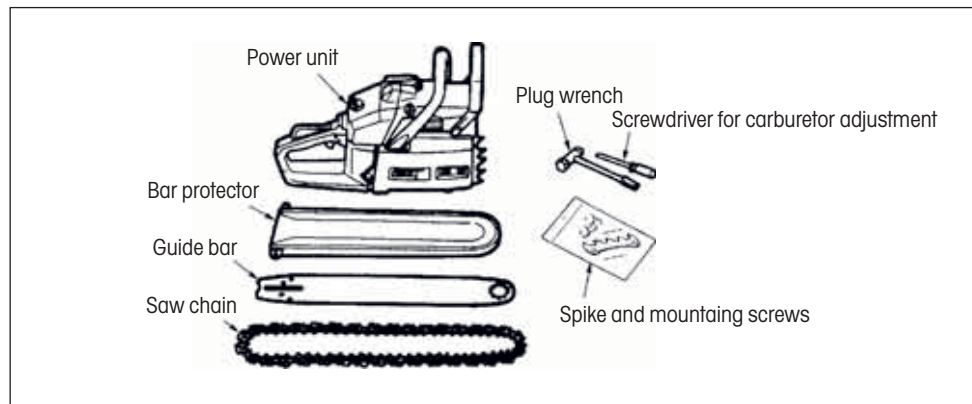

Open the box and install the guide bar and the saw chain on the power unit as follows:

⚠ WARNING! The saw chain has very sharp edges. Use thick protective gloves for safety.

1. Pull the guard towards the front handle to check that the chain brake is not engaged.
2. Loosen the nuts and remove the chain cover.
3. Install the attached spike to the power unit.
4. Gear the chain to the sprocket and, while fitting the saw chain around the guide bar, mount the guide bar to the power unit. Adjust the position of chain tensioner nut on the chain cover to the lower hole of guide bar.

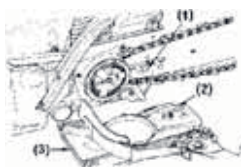

- (1) Hole
- (2) Tensioner nut
- (3) Chain cover

📖 NOTE: Pay attention to the correct direction of the saw chain.

Moving direction



5. Fit the chain cover to the power unit and fasten the nuts to finger tightness.
6. While holding up the tip of the bar, adjust the chain tension by turning the tensioner screw until the tie straps just touch the bottom side of the bar rail.

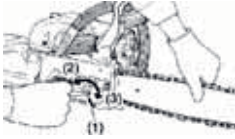

- (1) Tensioner screw
- (2) Loosen
- (3) Tighten

7. Tighten the nuts securely with the bar tip held up ($12 \sim 15 \text{ N} \cdot \text{m}$). Then check the chain for smooth rotation and proper tension while moving it by hand. If necessary, readjust with the chain cover loose.
8. Tighten the tensioner screw.

 **NOTE:** A new chain will expand its length in the beginning of use. Check and readjust the tension frequently as a loose chain can easily derail or cause rapid wear of itself and the guide bar.

5. OPERATING THE ENGINE

⚠ WARNING! It is very dangerous to run a chainsaw that mounts broken parts or lacks any parts. Before starting engine, make sure that all the parts including bar and chain are installed properly.

STARTING THE ENGINE

1. Fill fuel and chain oil tanks respectively, and tighten the caps securely.

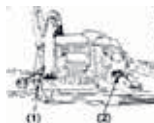

- (1) Chain oil
- (2) Fuel

2. Set the switch to T position.



- (1) Switch
- (2) Latch
- (3) Throttle lever
- (4) Throttle interlock

3. While holding the throttle lever together with the throttle interlock, push in the side latch and release the throttle lever to hold it at the starting position.
4. Pull out the choke knob to the closed position.



Choke knob

📖 NOTE: When restarting immediately after stopping the engine, set the Choke knob in the first-stage position (choke open and throttle lever in the starting position).

📖 NOTE: Once the choke knob has been pulled out, it will not return to the operating position even if you press down on it with your finger. When you wish to return the choke knob to the operating position, pull out the throttle lever instead.

5. While holding the saw unit securely on the ground, pull the starter rope vigorously.



⚠ WARNING! Do not start the engine while the chain saw hangs in one hand. The saw chain may touch your body. This is very dangerous.

6. When engine has ignited, first push in the choke knob to the first-stage position and then pull the starter again to start the engine.
7. Allow the engine to warm up with the throttle lever pulled slightly.

⚠ WARNING! Keep clear of the saw chain as it will start rotating upon starting of engine.

CHECKING THE OIL SUPPLY

⚠ WARNING! Make sure to set up the bar and the chain when checking the oil supply. If not, the rotating parts may be exposed. It is very dangerous.

After starting the engine, run the chain at medium speed and see if chain oil is scattered off as shown in the figure.

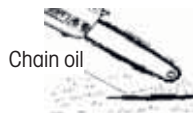

The chain oil flow can be changed by inserting a screwdriver in the hole on bottom of the clutch side. Adjust according to your work conditions.

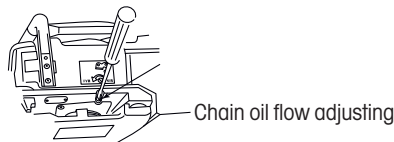

📖 NOTE: The oil tank should become nearly empty by the time fuel is used up. Be sure to refill the oil tank every time when refueling the saw.

ADJUSTING THE CARBURETOR



- (1) L needle
- (2) H needle
- (3) Idle adjusting screw

The carburetor on your unit has been factory adjusted, but may require fine tuning due to a change in operating conditions.

Before adjusting the carburetor, make sure that the provided air/fuel filters are clean and fresh and the fuel properly mixed.

When adjusting, take the following steps:

📖 NOTE: Be sure to adjust the carburetor with the bar chain attached.

6. FILLING THE OIL TANK AND FUEL TANK

TO FILL THE OIL TANK

⚠ WARNING! Never use used oil! Waste oil is harmful to the environment and may result in damage. Chain saw oil should be used to lubricate the saw chain and bar. Use oil that contains additives to reduce friction and wear and to prevent resin build-up on the bar and chain.

⚠ WARNING! Before filling the oil tank, make sure that the chainsaw is turned off.

1. Be sure to clean the surface around the oil tank cap to prevent dirt from getting inside.
2. Unscrew the oil tank cap and pour in the chain saw oil (260 ml tank capacity).
3. Screw the oil tank cap back on.
4. Before you start, check the oil supply: switch on the chainsaw and hold it over suitable bedding. If it is sufficiently lubricated, a light trail of dripping oil will form (fig. 12).

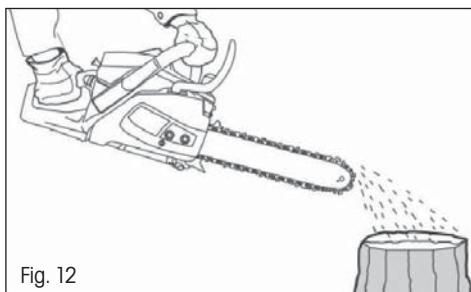

Fig. 12

⚠ WARNING! Always check the oil level. Do not operate the chain saw if there is insufficient oil to lubricate the chain.

Proper lubrication is essential to reduce chain and bar friction. Operating a chain saw with insufficient lubrication reduces performance and service life and causes fast chain and bar wear due to overheating. This chainsaw is equipped with an automatic lubrication system that provides the necessary amount of lubrication to the bar and chain. As the engine speed increases so does the oil supply to the bar.

TO FILL THE FUEL TANK

WARNING: When filling the tank:

The chainsaw must always be stopped and cooled.

Never smoke during refueling. It must not have flames or sparks near the fuel.

Before refueling, allow the chainsaw to cool completely. Do not attempt to refuel when the engine is hot. If fuel has been spilled, immediately stop refueling and do not start the engine. Clean up the spill and fill the machine in another location

Never fill the fuel tank to the flange; there is a risk of overflow.

Do not refuel in a closed and unventilated area.

The fuel used for this tool is a mixture of unleaded gasoline and registered engine lubricant. When mixing gasoline with oil, use only gasoline that does not contain ethanol or methanol.

Unleaded gasoline is a quality gasoline type. This will help to avoid damaging the fuel lines of the engine and other engine parts.

The recommended mixing ratio is 40:1 (make sure the mixing ratio is correct before filling the product).

a. Mixing

- Mix in a clean, empty container (supplied).
- Pour the oil into the container.
- Pour the fuel into the tank. Mix the mixture long enough (more than one minute) to get a good combination.

b. Filling the fuel tank

- Unscrew the fuel tank cap and remove it.
- Fill the tank slowly with the mixture. Do not exceed the maximum capacity (fill to 80% of its capacity preferably).
- Replace the cap on the fuel tank and tighten it
- Wipe any spillage around the unit if necessary

Note: To avoid damage and accidents, DO NOT USE OTHER MIXTURES AND OTHER TYPES OF OIL / PETROL

c. Storage of fuel

The fuel must be kept in a clean and safe container and always closed.

If you are not using the product for a long time, remove the fuel mixture and add it to a container.

Do not leave the fuel for a long time in the product. The fuel may clog the carburetor and the engine will not operate properly.

d. Disposal of fuel

When the fuel is no longer used or worn, please dispose of it in an authorized location. Check local laws regarding disposal of fuels

7. OPERATION

Before using the chainsaw, inspect the work area. This must be cleared. Remove any branches, obstacles and other items that may cause damage during cutting.

The unit should always be filled with fuel and be usable. Check the level of filling and refill when necessary.

STARTING THE ENGINE

1. Hold the front handle with one hand and take the chainsaw to the ground. Hold the rear handle by stepping on it.
2. Set the ignition switch to the I position (ON).
3. Press the primer about 4-5 times until fuel appears in the primer.
4. Pull the air damper lever toward you until it locks, the air damper will close.
5. Slowly pull the starter grip until you feel resistance, then pull the cable with a steady movement to a distance of no more than 50-60 cm. Repeat the procedure several times until the engine starts.
6. Press the throttle lock key and the throttle key, the carburettor air damper will open automatically, the damper lever will return to its original position.

⚠ WARNING! Do not allow the cable to be pulled all the way out before the starter reel has stopped. This will cause the starter motor to break and is not covered by the warranty.

TO STOP THE ENGINE

1. Release the throttle lock key and throttle key to allow the engine to idle.
2. To stop the engine, move the switch to the O position (OFF).

NOTE: To stop the engine in an emergency, engage the chain brake and move the switch to the "O" position.

CHAIN BRAKE

Starting shall always be done with the chain brake activated. The chain brake is a device that automatically stops the chain in case a backward movement occurs, causing the saw to jump. Normally, the brake is automatically activated by the inertia force.

It is also manually tightened by pushing the brake lever down and forward.

When the brake is running, a yellow sign comes out from the base of the brake lever.

To release the brake, pull the brake lever up until it clicks into place.

When the brake is in operation, release the trigger to slow down the engine speed. Continuous use when the brake is running causes the clutch to heat up and can cause problems.

When checking the machine before using it, check the operating condition of the brake by performing the following operations:

- ☼ Start the engine and grasp the handle firmly with both hands.
- ☼ While using the trigger to keep the chain in operation, push the brake lever down with the back of the left hand.
- ☼ When the brake is running and the chain is stopped, remove the hand from the throttle.
- ☼ Loosen the brake.

RELEASE OF THE CHAIN BRAKE

To use the chain saw again, the chain brake must be released. This must be done machine off and cooled. Pull the shield until it returns to its original position.

CHECKING THE LUBRICATION OF THE CHAIN

- Before checking the oil, make sure that the bar and the chain are in place.
- Once the engine is started, turns it at medium speed and checks that the chain oil is sprayed and traces off the ground.
- The oil flow of the chain is adjustable to obtain the proper flow. Insert a screwdriver on the clutch side.
- Turn the adjuster to obtain the correct flow rate for the job.
- The chainsaw must essentially consume the contents of the oil tank between each full of fuel. Do not forget to fill the oil tank when filling the machine with fuel.

RELEASE OF A JAMMED SAW

If the saw gets stuck during cutting, the operators should:

- Saw the saw and attach it securely to the cutting foot of the shaft (ie trunk side) or has a separate chord from the tool
- Pull the saw of the cluster while the branch is lifted, if necessary,
- If necessary, use a hand saw or a second chainsaw to release the chain saw.

CUTTING WORK

The tool should only be used to cut trees. Do not use it for other applications.

Do not attempt to remove the chainsaw when it is stuck during operation. Stop the machine and remove the wedge blade with a wedge.

Stick your feet well, keep a good balance and do not climb on the tree trunk.

Try not to work on a slope. However, if you have to work on a slope, always stand higher than the tree trunk.

Before bending a branch or trunk in bending, observe the direction of bending and finish the cut opposite the bending side to prevent the chain guide from getting stuck in the cut.

FELLING OF TREES

Examine the work area and estimate where the tree will fall. Start the machine as described above. Start by making a notch in the direction of fall chosen.

When the tree falls, shout or make a beep to alert people in the vicinity. When the shaft falls, move away from the cutting area.

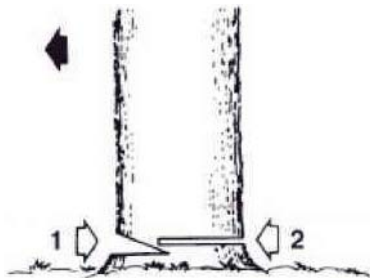

a. Trunk on the ground

Cut half of the trunk, turn it over and finish the cut on the other side.

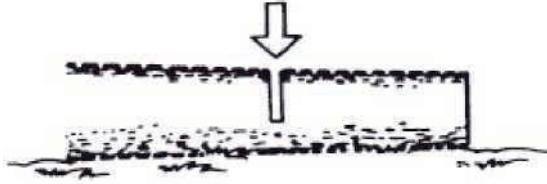
**b. Trunk in elevation**

Begin by cutting a first part from below and then from above. Then, on the second part, repeat this operation.

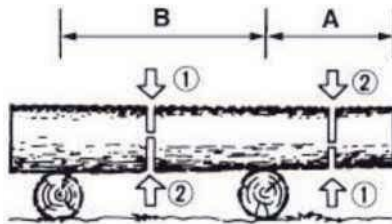
**c. Pruning of a felled tree**

Observe first the direction of flexion of the branch. Make a first notch on the side in flexion and finish the cut on the opposite side.

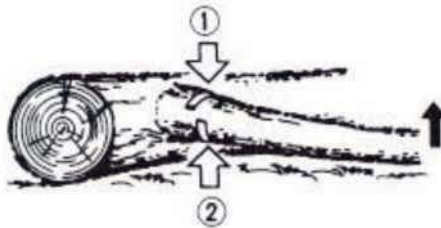
**d. Pruning a tree**

Begin pruning by nicking the tree from below and then finish at the top.

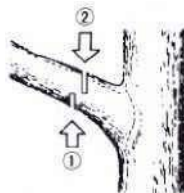

8. ADJUSTING THE CHAIN TENSION

⚠ ATTENTION! Due to the effect of higher temperatures, during operation the saw chain has a tendency to lengthen. A longer chain becomes loose and could slide off the guide bar.

- ✿ Loosen the sprocket cover fastening nuts.
- ✿ Make sure that the chain is seated in the guiding groove of the guide bar.
- ✿ Use a screwdriver to turn the chain tensioning screw (Fig. 5). Turn the tensioning screw until the required tension is achieved (you should lift the chain in the middle of the guide bar in the horizontal position to a height of 3 to 4 mm).
- ✿ Firmly tighten the guide bar fastening nuts.

⚠ ATTENTION! Do not tension the chain excessively. Excessive tension of a warm chain may result in excessively tension when it cools down.

9. CUTTING

⚠ ATTENTION! Before proceeding, please read the chapter "Safety instructions". We recommend that you gain experience by cutting smaller logs. In this way you will also get to know the chain saw.

- ✿ Always adhere to safety instructions. The chain saw may only be used for cutting wood. It is forbidden to cut any other materials. Vibrations and kickback differ for various materials. Do not use the chain saw as a lever for lifting, moving or splitting material. It is forbidden to attach any parts or jigs other than those specified in the technical documentation.
- ✿ It is not necessary to push the chain saw into the cut. When the engine is running at full speed, push the chain saw down lightly.
- ✿ If the chain jams in the cut, do not attempt to free it by pulling, rather stretch open the cut using a wedge or crowbar.

Safety brake (protection against kickback)

- ✿ This chain saw is equipped with an automatic chain brake that, if it works correctly, immediately stops the chain in the event of kickback. It is necessary to check the working order of the chain brake before every use of the chain saw. Run the chainsaw at full speed for 1 - 2 seconds and then tilt the front protective cover. The chain must stop immediately even when the engine is running at high speed. If the chain stops slowly or does not stop at all, please contact an authorised service centre.
- ✿ It is extremely important to check the working order of the chain brake and the sharpness of the chain before every use to ensure that the necessary level of safety in the event of a kickback is maintained. Removing safety accessories, incorrect maintenance or when using unsuitable guide bars or chains may, in the event of kickback, result in serious injuries.

Felling trees

- ☼ Decide about the direction in which the tree will fall, respecting the wind direction, incline angle of the tree and location of the branches, and consider all other factors before cutting.
- ☼ The area around the tree must be clear, without obstacles, and must enable a stable stance. The escape route must be passable.
- ☼ Cut a wedge into one third of the tree's diameter on the side to which the tree should fall. (see Fig. Felling, point 1)
- ☼ From the opposite direction perform a separation cut at a level above the wedge cut. (see Fig. Felling, point 2)
- ☼ The tree will fall in the direction towards the wedge cut. (see Fig. Felling, point 3)

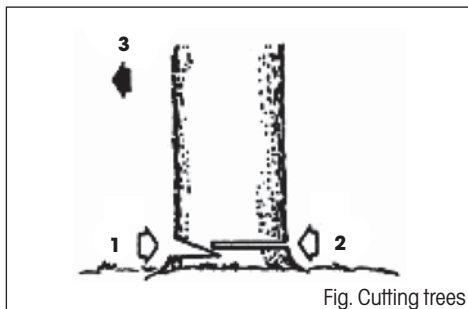

Fig. Cutting trees

⚠ ATTENTION! When felling trees, inform other people in the area about the potential danger. Felling trees requires experience and we do not recommend performing this task without the necessary experience.

Cutting logs

⚠ ATTENTION! Always maintain a stable stance. Do not step on logs.

⚠ ATTENTION! Before starting work, check that all components are in their place and that all nuts and bolts are tightened.

- ☼ The log being cut may roll away. Especially when cutting on a slope, always stand above the log being cut.
- ☼ Prevent kickback of the saw by following the instructions in chapter "Safety instructions".
- ☼ Before starting work, assess the direction of the force causing the cut trunk to bend. The final cut needs to always be done from the opposite side of where the bending force is acting to prevent the guide bar from being clamped inside the cut.
- ☼ Only carry the chain saw with the engine turned off and the guide bar protected by the protective cover.

Log lying on the ground

- ☼ Cut it halfway through, then roll it over and complete the cut from the other side.

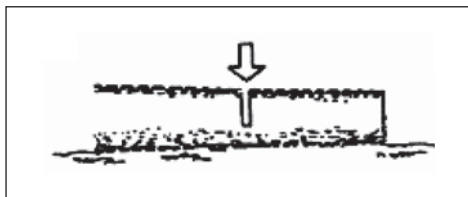

Log above the ground

- ✿ In part "A" make a cut from below to a third of the log and then complete the cut from above. In part "B" make a cut from above to a third of the log and then complete the cut from below.

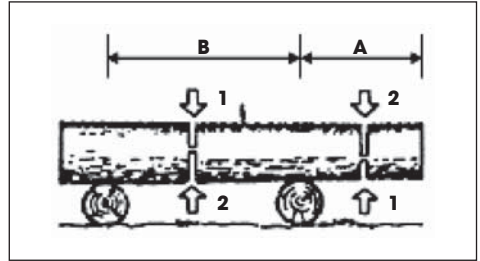

Removing a fallen tree

- ✿ First find out to which side the branch is bent. Then make the initial cut from the side of the bend and then complete the cut from the opposite side.

⚠ ATTENTION! A bent branch may spring up.

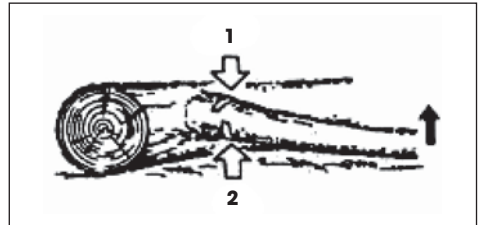

10. CLEANING AND MAINTENANCE

⚠ ATTENTION! Prior to cleaning, inspecting or repairing the chain saw, its engine must be turned off and cold and the spark plug must be removed to prevent accidentally starting the engine.

Maintenance after every use

- ✿ Remove the guide bar and use a brush to clean away accumulated sawdust from the entire chain saw. Use a spatula or screwdriver to remove stubborn dirt.
- ✿ Air filter:
Loosen the screw (Fig 1, point 11) and remove the air filter cover. Take out the filter insert and use a brush to remove the dust. If the filter insert is clogged with dust, dismantle into 2 parts and wash it out in petrol. If you are using compressed air, blow from the inside out.
- ✿ Lubricating hole:
Take off the guide bar and check the passage of the lubricating hole.
- ✿ Guide bar:
After taking off the guide bar, remove dust from the grooves and the lubricating hole.
- ✿ Other parts:
Check for any oil leaks, loose mounts and damaged main parts, particularly in the location where the handles and the guide bar are mounted. Any identified defects must be repaired before the chain saw is used again.

Cleaning the body of the chain saw

Keep the body of the chain saw clean. When cleaning, use a soft cloth dipped in a soap solution. Use this cloth to meticulously clean the body of the chain saw.

Maintaining the guide bar

- ✿ Most problems with the guide bar arise due to uneven wear. Uneven wear occurs mainly as a result of an incorrectly sharpened chain or an incorrectly set depth gauge. When the guide bar is worn out unevenly, the guiding groove is widened (see Picture). The result is a rattling chain and rivets falling off. The chain saw cannot be used for straight cuts. In such a case, replace the guide bar for a new one.
- ✿ Always check the condition of the guide bar before sharpening the chain. Using a worn out or damaged guide bar is very dangerous. Using a worn out or damaged guide bar will result in damage to the chain. Cutting with such a power tool will also be much more difficult and demanding.

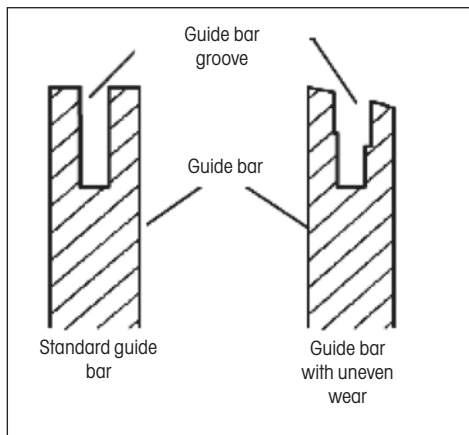

Normal maintenance of the guide bar

- ✿ Remove the guide bar from the body of the chain saw.
- ✿ Regularly remove sawdust from the guide bar groove. For cleaning use a spatula or a wire.
- ✿ Clean oily grooves at the end of every work day.
- ✿ Replace the guide bar if:
 - it is bent or cracked
 - its groove is very damaged or worn out

 **NOTE:** To replace the guide bar, follow the instruction contained in this user's manual. You will find the correct guide bar type in the technical specifications.

11. SHARPENING THE SAW CHAIN

Keep the saw chain sharp. Cutting will be significantly faster and most importantly safer. A blunt saw chain increases wear on the sprocket, guide bar, chain and engine. If you need to push on the saw and only sawdust with a few splinters are produced then this means that the chain is blunt.

For this task, we recommend that you contact an authorised service centre

Equipment necessary for sharpening a saw chain

- ✿ Round file as per technical specifications
- ✿ Depth gauge
- ✿ File guide
- ✿ Vice
- ✿ Medium-size flat file

Sharpening the teeth on the chain

Use the file guide set at an angle of 30° (mark A, see figure).

- ✿ Set the saw chain tension to the correct level.
- ✿ Fasten the guide bar in a vice so that you have the chain in a stable position.

NOTE: Do not fasten the chain itself.

- ✿ Push the round file, inserted in the file guide, into the groove between the top plate and the depth gauge on the chain. The chain should be touching both the top plate as well as the depth gauge (see figure)

NOTE: File in the middle of the guide bar.

NOTE: In the figure you can see the position of the file guide and the direction for filing the teeth on the left side of the chain.

- ✿ Place the file guide at the required angle (mark A, see figure). Check that the mark is at 30° on the file guide aligned with the centre of the guide bar. This will ensure that you will file at an angle of 30° .
- ✿ File the tooth in the direction from inside out (in direction B, see figure) until it is sharp. File only in this direction.

NOTE: Two to three passes of the file should be sufficient to sharpen the tooth.

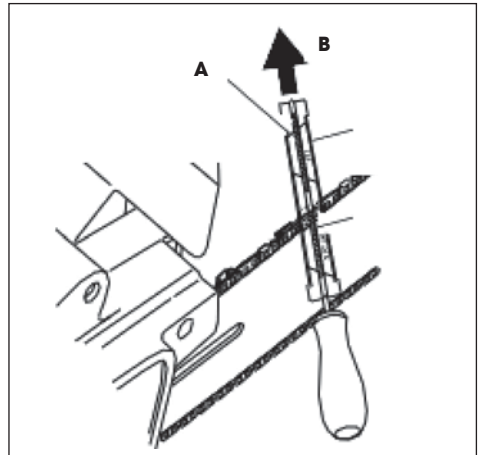

Filing the depth gauge

As a result of sharpening the teeth on the chain, the depth gauge tolerance is reduced. After every second or third sharpening, it is necessary to adjust the depth gauge setting.

- ✿ Place the depth gauge adjustment jig (see fig., point 1) firmly on the top edge of two teeth. Make sure that the groove of the jig is in the groove of the depth gauge (see fig., point 2.)
- ✿ Use a medium-sized flat file (see fig., point 3). File the depth gauge (see fig., point 4) to the level of the depth gauge adjustment jig.
- ✿ Remove the depth gauge adjustment jig. Using a flat file, round the front edge of the depth gauge (see figure). When filing, adhere to the prescribed values (see fig., point 5).

NOTE: After the chain has been sharpened by hand several times, have the saw chain sharpened at an authorised service centre or sharpen it on a special sharpening machine. This will renew the even sharpness of all teeth.

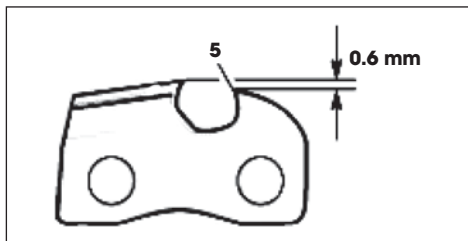
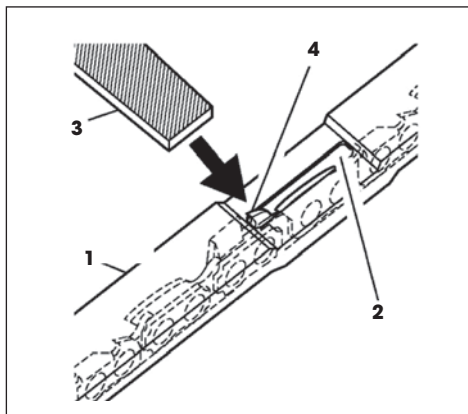

12. REPLACING THE SAW CHAIN

⚠ ATTENTION! When replacing the saw chain, do not clamp the chain saw or the guide bar in a vice.

Always replace the chain if the teeth are excessively worn out and they cannot be sharpened or if the chain snaps. Use only an original spare chain according to the specifications in this user's manual. When replacing the saw chain, always also replace the cogged wheel of the sprocket. This will ensure the correct position of the chain during movement. (Note: You will find the specifications of the correct chain type and the cogged wheel in the technical specifications.)

- ⚙ Loosen and remove the bar guide bolt.
- ⚙ Remove the sprocket cover.
- ⚙ Remove the saw chain.
- ⚙ Wind the new chain around the cogged wheel, then along the top groove of the guide bar and around the guide bar nose.

⚠ ATTENTION! Check that the saw teeth are facing in the correct direction. Put on the chain so that the teeth on the top side of the guide bar are facing towards the guide bar nose (see figure).

- ⚙ Before placing the sprocket cover into position, check that the chain tensioning pin is inserted into the adjustment hole on the guide bar.
- ⚙ Put the sprocket cover back on to the body of the chain saw.
- ⚙ Fasten the sprocket cover using the guide bar bolt.

⚠ ATTENTION! Only tighten the bolt by hand.

- ⚙ Adjust the tension of the saw chain.
- ⚙ Tighten the guide bar bolt.

⚠ ATTENTION! Check that you have not placed the saw chain on the guide bar in the opposite direction. Otherwise, the chain saw will exhibit excessive vibrations and will not cut.

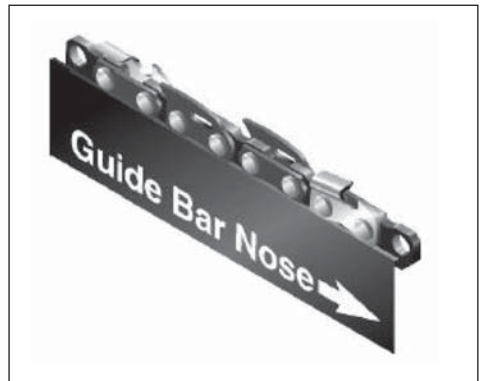

13. MAINTENANCE TABLE

Please understand that the following maintenance intervals apply only to standard work conditions. In the event that your daily work is more demanding than normal, the maintenance intervals must be shortened correspondingly.		Before every use	After every pause for adding fuel	Every week	When damage of defect arises	As required
The entire machine	Check for: leaks, cracks and wear	X	X			
Check: trigger switch, starter, throttle lever and throttle lock lever	Check working order	X	X			
Chain brake	Check working order	X	X			
	Check performed by an authorised repair centre				X	
Fuel tank and oil tank	Check for: leaks, cracks and wear	X	X			
Fuel filter	Inspection and cleaning			X		
	Replacement of filtration element				X	Every 6 months
Chain lubrication	Check the power output	X	X			
Chain	Check for: damage, sharpness and wear	X	X			
	Check the tension	X	X			
	Sharpening: check the filing depth				X	
Guide bar	Check for: damage and wear	X	X			
	Cleaning of grooves and oil lines	X				
	Rotation, lubrication of drive wheel and removal of flashes			X		
	Replace				X	
Sprocket	Check for: damage and wear			X		Replacement with every new chain
Connecting piece	Check for: damage and wear			X		
	Replace				X	
Chain retainer	Check for: damage and wear	X	X			
	Replace				X	
All accessible nuts and bolts (excluding bolts on the carburettor)	Check and tighten			X		
Air filter	Clean	X				
	Replace				X	Every 6 months
Ribs of the cylinder and slits in the starter cover	Clean			X		
Pull cord	Check for: damage and wear			X		
	Replace				X	
Carburettor	Check idling speed (the chain must not turn at idling speed)	X	X			
Spark plug	Check the distance of the electrodes			X		
	Replace				X	Every 6 months
Anti-vibration system	Check for: damage and wear			X		

14. TROUBLESHOOTING

CAUTION: always turn off the unit and disconnect the spark plug before carrying out the checks recommended in the table, except for the cases where the unit needs to be running.

When all possible causes have been checked and the problem remains unsolved, please contact an authorised service centre. When you identify a problem that is not included in the table, please contact an authorised service centre.

PROBLEM	POSSIBLE CAUSES	SOLUTION
The motor cannot be started or stops several seconds after starting. (Make sure that the switch is in position „I“)	<ol style="list-style-type: none"> 1. The spark plug is not firing 2. The motor is flooded 	<ol style="list-style-type: none"> 1. Check that the spark plug is firing. If the spark plug is not firing, repeat the test with a new spark plug (WXL7T). 2. Take out the spark plug and pull the starting cord several times. Then reinsert the cleaned spark plug and start without using the choke.
The motor starts but does not properly increase its speed or does not run properly at high speeds.	The carburettor must be adjusted.	Contact an authorised service centre to have the carburettor adjusted
The motor does not reach full speed and/or emits too much smoke.	<ol style="list-style-type: none"> 1. Check the petrol - oil mixture. 2. Dirty air filter. 3. The carburettor must be adjusted. 	<ol style="list-style-type: none"> 1. Only use fresh petrol and oil suitable for two-stroke engines. 2. Clean it; see instructions in chapter 11. 3. Contact an authorised service centre to have the carburettor adjusted
The engine starts, works and accelerates, but does not maintain idling speed.	The carburettor must be adjusted.	Contact an authorised service centre to have the carburettor adjusted.
The guide bar and chain heat up and smoke while running	<ol style="list-style-type: none"> 1. Empty chain oil tank 2. Chain is overly tensioned 3. Lubrication system not working properly 	<ol style="list-style-type: none"> 1. The oil tank must be filled up every time when the fuel tank is filled. 2. Tensioning the chain; see instructions in chapter 5. 3. Allow it to run at maximum speed for 15-30 seconds. Stop and check whether oil is dripping from the tip of the guide bar. If there is oil there, the faulty operation may be caused by a loose chain or damaged guide bar. If there is no oil there, contact an authorised service centre
The motor starts but the chain is not running. CAUTION: when the motor is running, never touch the chain	<ol style="list-style-type: none"> 1. Chain brake engaged 2. Chain is overly tensioned 3. Guide bar and chain installation 4. Damaged chain and/or guide bar 5. Damaged clutch and/or pinion 	<ol style="list-style-type: none"> 1. Disengage the chain brake; see chapter 7. 2. Tensioning the chain; see instructions in chapter 9. 3. See instructions in chapter 5. 4. See instructions in chapter 11. and 13. 5. If necessary, replace it; contact an authorised service centre

15. TECHNICAL PARAMETERS

Power unit

1	Displacement (cm ³):	25.4
2	Fuel:	Mixture (Gasoline 25 : Two-cycle oil 1)
3	Fuel tank capacity(ml)	280
4	Chain oil:	Motor oil SAE# 10W-30
5	Oil tank capacity(ml):	200
6	Carburetor:	Diaphragm type
7	Ignitionsystem:	Pointless (CDI)
8	Spark plug:	LD L8RTF
9	Oil feeding system:	Automatic pump
10	Sprocket (Teeth × Pitch):	6T × 3/8"
11	Dimensions (L × W × H) mm:	300 × 260 × 240mm
12	Dry weight Power unit only (kg):	3.2

Cutting heard

13	Guide bar	
14	Type:	Sprocket nose
15	Size:	10"
16	Saw chain	
17	Pitch (in.(mm)):	3/8(9.53)
18	Gauge(in.(mm)):	0.05(1.27)

Specification are subject to change without notice

If you find that the vibrations being transferred to the handle have become noticeably worse compared to the condition when the chain saw was new, check the wear on the silentblocks (rubber coated mounting elements) and if necessary contact an authorised service centre to have them replaced.

⚠ ATTENTION! Working with a chain saw with an incorrectly working vibration shock absorption system may lead to health problems.

16. DISPOSAL

INSTRUCTIONS AND INFORMATION REGARDING THE DISPOSAL OF USED PACKAGING MATERIALS

Dispose of used packaging material at a site designated for waste in your municipality.



The machine and its accessories are manufactured from various materials, e.g. metal and plastic.

Take damaged parts to a recycling centre. Inquire at the relevant government department.



This product meets all the basic requirements of EU directives that apply to it.

Changes in the text, design and technical specifications may be made without prior notice and we reserve the right to make these changes.

User's manual in the original language.

17. DECLARATION OF CONFORMITY

FAST[®]

FAST ČR, a.s.
 U Sanitasu 1621, 251 01 Říčany, Czech Republic
 tel.: +420 323 204 111, fax: +420 323 204 110

EU DECLARATION OF CONFORMITY

Product / brand: Gasoline Chain Saw / **FIELDMANN**

Type / model: **FZP 25410-B** as factory model LD825
 Engine 25,4cm³ (1E34F); 0,7kW; max. speed 12000 rpm;
 L_{pA} = 100,4 dB(A); L_{wA} = 110 dB(A)

Manufacturer: FAST ČR, a.s.
 U Sanitasu 1621, 251 01 Říčany, Czech Republic
 VAT no: CZ24777749

This declaration of conformity is issued under the sole responsibility of the manufacturer.

The object of the declaration described above is in conformity with the relevant Union harmonization legislation:

Directive MD 2006/42/EC Directive EMC 2014/30/EU
 Directive NEOE 2000/14/EC Directive RoHS 2011/65/EU+(EU)2015/863
 Directive Emission of gaseous 2016/1628/EU

The relevant harmonized standards and the other technical specifications:

EN ISO 11681-2:2022 EN ISO 14982:2009
 EN ISO 12100:2010

CE

Place of issuance: Prague
Date of issuance: 21. 08. 2023

Name: Petr Uher - Responsible Person
Signature:

FAST[®] **FAST ČR, a.s.**⁻⁸⁷⁻
 U Sanitasu 1621, 251 01 Říčany
 tel.: +420 323 204 111
 IČO: 247 77 249, DIČ: CZ 247 77 749

IČO:24777749, DIČ:CZ24777749

Bankovní spojení: Komerční banka Praha 1, č.ú. 89309011/0100, ČSOB Praha 1, č.ú. 8010-0116233383/0300
 Česká spořitelna Praha 4, č.ú. 2375682/0800



FIELDMANN®
Home & Garden Performance

Model /Modell /Modelis:

**Záruční list / Záručný list /
Warranty Certificate / Jótállási jegy /
Garantijos taisyklės / Karta Gwarancyjna**

Výrobní číslo
Výrobné číslo
Serial No.
Szériaszám
Serijos Nr.
Numer seryjny

Razítko a podpis prodejce
Pečiatka a podpis predajcu
Dealer's stamp
A kereskedő bélyegzője
Pardavėjo antspaudas
Pieczęćka i podpis sklepu

Datum prodeje
Dátum predaja
Date of purchase
A vásárlás dátuma
Pardavimo data
Data zakupu

Záruční podmínky

Prodávající poskytuje kupujícímu na výrobek záruku v trvání 24 měsíců od převzetí výrobku kupujícím. Záruka se poskytuje za dále uvedených podmínek. Záruka se vztahuje pouze na nové spotřební zboží prodané spotřebiteli pro běžné domácí použití. Práva z odpovědnosti za vady (reklamací) může kupující uplatnit buď u prodávajícího, u kterého byl výrobek zakoupen nebo v níže uvedeném autorizovaném servisu. Kupující je povinen reklamaci uplatnit bez zbytečného odkladu, aby nedocházelo ke zhoršení vady, nejpozději však do konce záruční doby. Kupující je povinen poskytnout při reklamaci součinnost nutnou pro ověření existence reklamované vady. Do reklamačního řízení se přijímá pouze kompletní a z důvodů dodržení hygienických předpisů neznehodnocený výrobek. V případě oprávněné reklamace se záruční doba prodlužuje o dobu od okamžiku uplatnění reklamace do okamžiku převzetí opraveného výrobku kupujícím nebo okamžiku, kdy je kupující po skončení opravy povinen výrobek převzít. Kupující je povinen prokázat svá práva reklamováním (doklad o zakoupení výrobku, záruční list, doklad o uvedení výrobku do provozu...).

Záruka se nevztahuje zejména na:

- vady, na které byla poskytnuta sleva
- opotřebení a poškození vzniklé běžným užíváním výrobku
- poškození výrobku v důsledku neodborně či nesprávné instalace, použití výrobku v rozporu s návodem k použití, platnými právními předpisy a obecně známými a obvyklými způsoby používání, v důsledku použití výrobku k jinému účelu, než ke kterému je určen
- poškození výrobku v důsledku zanedbané nebo nesprávné údržby
- poškození výrobku způsobené jeho znečištěním, nehodou a zásahem vyšší moci (živelná událost, požár, vniknutí vody...)
- vady funkčnosti výrobku způsobené nevhodnou kvalitou signálu, rušivým elektromagnetickým polem apod.
- mechanické poškození výrobku (např. ulomení knoflíku, pád...)
- poškození způsobené použitím nevhodných médií, náplní, spotřebního materiálu (baterie) nebo nevhodnými provozními podmínkami (např. vysoké okolní teploty, vysoká vlhkost prostředí, otřesy...)
- poškození, úpravu nebo jiný zásah do výrobku provedený neoprávněnou nebo neautorizovanou osobou (servisem)
- případy, kdy kupující při reklamaci neprokáže oprávněnost svých práv (kdy a kde reklamovaný výrobek zakoupil)
- případy, kdy se údaje v předložených dokladech liší od údajů uvedených na výrobku
- případy, kdy reklamovaný výrobek nelze ztotožnit s výrobkem uvedeným v dokladech, kterými kupující prokazuje svá práva reklamováním (např. poškození výrobního čísla nebo záruční plombu přístroje, prepisované údaje v dokladech...)

Záručné podmienky

Predávajúci poskytuje kupujúcemu na výrobok 24 mesiacov záruku od jeho prevzatia kupujúcim. Záruka sa poskytuje ďalej za nižšie uvedených podmienok. Záruka sa vzťahuje iba na spotrebný tovar predaný spotrebiteľovi na bežné domáce použitie. Práva zo zodpovednosti za chyby (reklamácie) môže kupujúci uplatniť buď u predávajúceho, u ktorého bol výrobok zakúpený alebo v nižšie uvedenom autorizovanom servise. Kupujúci je povinný reklamáciu uplatniť bez zbytočného odkladu, aby nedochádzalo ku zhoršeniu chyby, najneskôr však do konca záručnej doby. Kupujúci je povinný pri reklamacii spolupracovať pri overení existencie reklamovanej chyby. Do reklamačného procesu sa prijíma iba kompletná a z dôvodu dodržania hygienických predpisov neznehodnotený výrobok. V prípade oprávnenej reklamácie sa záručná doba predlžuje o dobu od okamžiku uplatnenia reklamácie do okamžiku prevzatia opraveného výrobku kupujúcim, kedy je kupujúci po skončení opravy povinný výrobok prevziať. Kupujúci je povinný preukázať svoje práva reklamovať (doklad o zakúpení výrobku, záručný list, doklad o uvedení výrobku do prevádzky...).

Záruka sa nevztahuje na:

- chyby, na ktoré boli poskytnuté zľavy
- opotrebenia a poškodenia vzniknuté bežným užívaním výrobku
- poškodenie výrobku v dôsledku neodborné či nesprávne inštalácie, použitie výrobku v rozpore s návodom na použitie s platnými právnymi predpismi a všeobecne známymi a obvyklými spôsobmi používania, v dôsledku použitia výrobku za iným účelom, než na ktorý je určený
- poškodenie výrobku v dôsledku zanedbanej alebo nesprávnej údržby
- poškodenie výrobku spôsobené jeho znečistením, nehodou a zásahom vyššej moci (živelná udalosť, požiar, vniknutievody...)
- chyby funkčnosti výrobku spôsobené nevhodnou kvalitou signálu, rušivým elektromagnetickým polom a pod.
- mechanické poškodenie výrobku (napr. zlomenie gombíka, pád...)
- poškodenie spôsobené použitím nevhodných médií, náplní, spotrebného materiálu (batérie) alebo nevhodnými prevádzkovými podmienkami (napr. vysoké teploty v okolí, vysoká vlhkosť prostredia, otrasy...)
- poškodenie, úpravu alebo iný zásah do výrobku spôsobený neoprávněnou alebo neautorizovanou osobou (servisom)
- prípady, keď kupujúci pri reklamacii nepreukáže oprávněnost svojich práv (kedy a kde reklamovaný výrobok zakúpil)
- prípady, keď sa údaje v predložených dokladoch líšia od údajov uvedených na výrobku
- prípady, keď reklamovaný výrobok sa neshoduje s výrobkom uvedeným v dokladoch, ktorými kupujúci preukazuje svoje práva reklamováním (napr. poškodenie výrobného čísla alebo záručnej plombu prístroja, prepisované údaje dokladoch...)

Conditions of guarantee

This product is warranted for the period of 24 months from the date of purchase to the end-user. Warranty is limited to the following conditions. Warranty is referred only to the customer goods using for common domestic use. The claim for service can be applied either at dealer's shop where the product was bought, or at below mentioned authorized service shops. The end-user is obligated to set up a claim immediately when the defects appeared but only till the end of warranty period. The end-user is obligated to cooperate to certify the claiming defects. Only completed and clean (according to hygienic standards) product will be accepted. In case of eligible warranty claim the warranty period will be prolonged by the period from the date of claim application till the date of taking over the product by end-user, or the date the end-user is obligated to take it over. To obtain the service under this warranty, end-user is obligated to certify his claim with duly completed following documents: receipt, certificate of warranty, certificate of installation...

This warranty is void especially if apply as follows:

- Defects which were put on sale.
- Wear-out or damage caused by common use.
- The product was damaged by unprofessional or wrong installation, used in contrary to the applicable instruction manual, used in contrary to legal enactment and common process of use or used for another purpose which has been designed for.
- The product was damaged by uncareful-for insufficient maintenance.
- The product was damaged by dirt, accident of force majeure (natural disaster, fire, flood, ...)
- Defects on functionality caused by low duality of signal, electromagnetic field interference etc.
- The product was mechanically damaged (e.g. broken button, fall...)
- Damage caused by use of unsuitable media, fillings, expendable supplies (batteries) or by unsuitable working conditions (e.g. high temperatures, high humidity, quakes, ...)
- Repair, modification or other failure action to the product by unauthorized person.
- End-user did not prove enough his right to claim (time and place of purchase).
- Data on presented documents differs from data on products.
- Cases when the claiming product can not be identified according to the presented documents (e.g. the serial number or the warranty seal has been damaged).

Autorizovaná servisní střediska / Autorizované servisné strediská / Authorized service centres

FASTČR, a. s.
U Sanitatu 1621 CZ
251 01 Říčany
Česká republika
Tel.: +420/ 323 204 120
Fax: +420/ 323 204 121
servis.praha@fastcr.cz
www.fastcr.cz

FAST ČR, a. s.
Cejl 31
CZ 602 00 Brno
Česká republika
Tel.: +420/ 531 010 295
Fax: +420/ 531 010 296
servis.brno@fastcr.cz
www.fastcr.cz

Fast Plus, a. s.
Na Pántoch 18
SK 831 06 Bratislava
Slovenská republika
Tel.: +421/ 249 105 811
Fax: +421/ 249 105 810
fastplus@fastplus.sk
www.fastplus.sk

Jótállási jegy

■ A termék gyártója: FAST ČR, a.s. (U Sanitasa 1621, Řičany u Prahy 251 01, Csehország)
■ A FAST Hungary Kft. (2310 Szigetszentmiklós, Kántor út 10.) mint a termék magyarországi importőre a jótállási jegyen feltüntetett típusú és gyártási számú készülékre (vásárlástól) a fogyasztók számára az alábbi feltételek szerint:
■ A FAST Hungary Kft. a termékre a fogyasztó részére történő átadástól (vásárlástól), illetve ha az üzembe helyezését a termék értékesítő vállalkozás vagy annak megbízottja végzi, az üzembe helyezéstől számított 24 hónapig, míg 250.000,- Ft eladási ár felett 36 hónapig tartó időtartamra vállal jótállást. Ha a terméket a fogyasztó az átadástól számított fél éven belül helyzeti hibára, akkor a jótállási határidő a termék átadásától kezdődik. A termék alkotórészeire és tartozékaira (pl. akkumulátor) a jótállási idő a termék átadásától számított 12 hónap.
■ A jótállási igény a jótállási jeggyel, az átadástól (ha releváns az üzembe helyezésétől) számított (i) 1 évig - 100.000,- Ft eladási árát meg nem haladó termék esetén; (ii) 2 évig - 250.000,- Ft eladási árát meg nem haladó termék esetén; (iii) 3 évig - 250.000,- Ft eladási árát meghaladó termék esetén a terméket értékesítő vállalkozásnál, annak székhelyén, vagy bármely telephelyén, főkötelezőn, illetve mindhárom esetben a jótállási jegyen feltüntetett hivatalos szerviznél közvetlenül is, míg az előző (i) pont szerinti esetben, az 100.000,- Ft eladási árát meg nem haladó termék esetén a 13. hónaptól a 24. hónapig kizárólag a hivatalos szerviznél érvényesíthető.
■ Jótállási jegy hiányában a fogyasztói szerződés megkötését bizonyítottnak kell tekinteni, ha a fogyasztó bemutatja a termék ellenértékének megfizetését hitelt érdemlően igazoló bizonylatot. Mindezek érdekében kérjük tisztelt Vásárlóinkat, hogy őrizzék meg a fizetési bizonylatot is. A jótállási időn belüli meghibásodás esetén a fogyasztó - választása szerint - (i) a hibás termék díjmentes kijavítását vagy kicserélését követelheti, kivéve, ha a választott igény teljesítése lehetetlen, vagy ha az a jótállásra kötelezettnek a fogyasztó által érvényesíteni kívánt másik igény teljesítésével összehasonlítva aránytalan többletköltséget eredményezne, vagy (ii) ha a kötelezett a kijavítást, illetve kicserélést nem vállalata, vagy e kötelezettségének megfelelő határidőn belül, a fogyasztó érdekeit kímélve nem tud eleget tenni, vagy ha a fogyasztónak a kijavításához vagy kicseréléséhez fűződő érdeke megszűnt, akkor a fogyasztó megfelelő árleszállítást igényelhet, vagy a hibát a kötelezett költségére maga kijavíthatja vagy mással kijavíthatja vagy elállhat a szerződéstől. Jelentéktelen hiba miatt

elállásnak nincs helye. A fogyasztó a választott jogáról másra térhet át. Az áttéréssel okozott költséget köteles a jótállásra kötelezettnek megfizetni, kivéve, ha az áttérésre a jótállásra kötelezett adott okot, vagy az áttérés egyébként indokolt volt.
■ Ha a jótállási időtartam alatt a termék első alkalommal történő javítása során megállapított nyer, hogy a termék nem javítható, a fogyasztó eltérő rendelkezése hiányában a termék a megállapítást követő 8 napon belül kicserélésre kerül. Ha a termék cseréjére nincs lehetőség, a fogyasztó által bemutatott, a termék ellenértékének megfizetését igazoló bizonylaton feltüntetett vételárát nyolc napon belül kell a fogyasztó részére visszatéríteni.
■ Ha a jótállási időtartam alatt a termék három alkalommal történő kijavítást követően ismét meghibásodik, a fogyasztó eltérő rendelkezése hiányában, valamint ha a fogyasztó nem igényli a vételár arányos leszállítását, és nem kívánja a terméket a jótállásra kötelezett költségére kijavítani vagy mással kijavíttatni, a termék 8 napon belül kicserélésre kerül. Ha a termék kicserélésére nincs lehetőség, a fogyasztó által bemutatott, a termék ellenértékének megfizetését igazoló bizonylaton feltüntetett vételárát nyolc napon belül kell a fogyasztó részére visszatéríteni.
■ Ha a termék kijavítására a Kijavítási igény közlésétől számított 30. napig nem kerül sor, a fogyasztó eltérő rendelkezése hiányában a termék a 30 napos határidő eredménytelen eltelte követő nyolc napon belül cserélési kéri. Ha a termék cseréjére nincs lehetőség, a fogyasztó által bemutatott, a termék ellenértékének megfizetését igazoló bizonylaton feltüntetett vételárát a 30 napos kijavítási határidő eredménytelen eltelte követő nyolc napon belül kell a fogyasztó részére visszatéríteni.
■ A fogyasztó a hiba felfedezését követően késedelem nélkül, legkésőbb a felfedezéstől számított 2 hónapon belül köteles a hibát közölni. A bejelentés kapcsán kérjük vegye figyelembe, hogy a **jótállási igény kizárólag a jótállási határidőben érvényesíthető! Mindazonáltal a jótállási határidő meghosszabbodik a javításra átadás napjától kezdve azzal az idővel, amely alatt a fogyasztó a terméket a hiba miatt rendeltetészerűen nem használhatta.** Ha a jótállásra kötelezett jótállási kötelezettségének megfelelő határidőben nem tesz eleget, a jótállási igény a fogyasztó erre irányuló felhívásában tüzött megfelelő határidő eltelte után számított 3 hónapon belül akkor is érvényesíthető bíróság előtt, ha a jótállási idő már eltelt. E határidő elmulasztása jogvesztéssel jár. A jótállási kötelezettség teljesítésével kapcsolatban felmerülő költségek a jótállás kötelezettjévé terhelik.

■ A 151/2003. (IX.22.) Korm.rendeletben meghatározott tartós fogyasztási cikk meghibásodása miatt a vásárlástól (üzembe helyezésétől) számított három munkanapon belül érvényesített csereigény esetén a terméket értékesítő vállalkozás nem hivatkozhat aránytalan többletköltségre, hanem köteles a tartós fogyasztási cikket kicserélni, feltéve, hogy a meghibásodás a rendeltetészerű használatot akadályozza (és a csere nem lehetetlen).
■ Kijavítás esetén a fogyasztási cikkbe csak új alkatrészt kerülhet beépítésre. Javítási- vagy csereigény esetén törekedni kell arra, hogy a kijavítás vagy kicserélés 15 napon belül megtörténjen. Ha a javítás vagy csere időtartama a 15 napot meghaladja, akkor jótállást kell a fogyasztó számára a csere várható időtartamáról. A tájékoztatás a fogyasztó előzetes hozzájárulása esetén elektronikus úton, vagy a fogyasztó általi átvétel igazolására alkalmas más módon történik. A rögzített bektöltési, illetve a 10kg-nál súlyosabb, vagy tömegközlekedési eszközön kézi csomagként nem szállítható fogyasztási cikket – járművek kivételével – az üzemeltetés helyén kell megjavítani. Ha a javítás az üzemeltetés helyén nem végezhető el, a le- és felszerelésről, valamint az el- és visszaszállításról a jótállás kötelezettje, vagy – a javítószolgálatnál közvetlenül érvényesített kijavítási igény esetén – a javítószolgálat gondoskodik.

■ Nem tartozik jótállás alá a hiba és a jótállásra kötelezett mentesül a jótállási kötelezettség alól, ha bizonyítja, hogy a hiba oka a termék fogyasztó részére való átadását követően keletkezett, így például ha a hibát ■ nem rendeltetészerű használat, használati útmutató figyelmen kívül hagyása, helytelen szállítás vagy tárolás, leejtés, rongálás, elemi kár, készüléken kívüli ok (pl. hálózati feszültség megengedettnél nagyobb ingadozása) ■ illetéktelen átalakítás, beavatkozás, nem hivatalos szerviz által végzett szakszerűtlen javítás ■ fogyasztó feladatát képező karbantartási munkák elmulasztása ■ normál, természetesen elhasználódásra visszavezethető (pl. elem lemerülése) vagy üzemszerű kopásnak tulajdonítható meghibásodás okozta. A jótállás a fogyasztó jogszabályból eredő jogait, így különösen a Polgári Törvénykönyv szerinti kellékszavatossági illetve termékszavatossági jogait nem érinti.
■ Tájékoztatjuk, hogy a fogyasztóvédelmi törvényben meghatározott fogyasztói jogvita bíróságon kívüli rendezése érdekében Ön a megyei (főváros) kereskedelmi és iparkamarák által működőtetett békéltető testület eljárását is kezdeményezheti (a békéltető testületek elérhetősége: <https://bekteltetes.hu/index.php?id=testuletek>).

Hivatalos szervíz / Autoryzowana sieć serwisowa

revision 01 / 2021

Fast Hungary Kft.
2310, Szigetszentmiklós
Kántor u. 10
Hungary
Tel.: + 36/ 23 330 830
Fax: + 36/ 23 330 8274
fasthungary@fasthungary.hu
www.fasthungary.hu

A kereskedő tölti ki

Megnevezés:.....

Típus:..... Gyártási szám:

A termék azonosításra alkalmas részeinek meghatározása (ha alkalmazható):

Vásárlást igazoló bizonylat száma:

A vásárlás (üzembe helyezés) időpontja: 20..... hó.....nap.

Kereskedő bélyegzője:

Kereskedő aláírása:

Kereskedő címe:

Javítás esetén alkalmazandó

A kereskedő vagy szerviznél történő közvetlen bejelentés esetén a szerviz tölti ki

A jótállási igény bejelentésének időpontja:

Javításra átvétel időpontja:

Hiba oka:

Javítás módja:

A termék fogyasztó részére való visszaadásának időpontja:

A jótállás – kijavítás időtartamával meghosszabbított – új határideje:

Szerviz pecsétje:

Kereskedő pecsétje:

Kicserélés esetén alkalmazandó

A jótállási igény kicseréléssel került rendezésre.

A csere időpontja:

Kereskedő bélyegzője:

Tisztelt Fogyasztó!

Köszönjük, hogy termékünket választotta. Cégünk és szervizünk elérhetősége:

FAST Hungary Kft. H-2310 Szigetszentmiklós, Kántor út 10. Tel.: 06-23-330-905; 06-23-330-830;

Fax: 06-23-330-827, E-mail: szerviz@fasthungary.hu

Garantijos taisyklės

Šiam gaminiai suteikiama 24 mėnesių nuo įsigijimo datos garantija. Garantija apsiriboja žemiau pateikiamomis sąlygomis. Garantija skirta tik gaminiais, skirtiems buitiniam naudojimui. Dėl garantinio remonto pirkėjas gali kreiptis į pardavėjo parduotuvę, kurioje gaminį pirkė, arba į nurodytus įgaliotus techninės priežiūros centrus. Galutinis naudotojas įsipareigoja pateikti pretenziją nedelsiant po defekto atsiradimo, tačiau tik iki garantijos galiojimo periodo pabaigos. Galutinis naudotojas įsipareigoja bendradarbiauti patvirtinant gaminio defektus, dėl kurių pateikia pretenziją. Priimtas bus tik pilnai sukomplektuotas ir švarus (pagal higienos standartus) gaminys. Jei pretenzija dėl garantinio remonto bus pagrįsta, gaminio garantijos galiojimo periodas bus prailgintas atitinkamai periodu nuo pretenzijos pateikimo datos iki galutinio naudotojas pasimus sutaisyti gaminį arba iki datos, kada galutinis naudotojas turėtų pasiimti sutaisytą gaminį. Norėdamas gauti garantinio remonto paslaugas, galutinis naudotojas turi patvirtinti pretenziją pilnai užpildytais sekančiais dokumentais: pirkimo kvitu, garantiniu talonu, instaliavimo sertifikatu. . .

Garantija netaikoma: ■ Nukainotoms (brokuotoms) prekėms. ■ Įprastinai susidėvinčioms gaminio dalims ■ Gedimams, atsiradusiems neprofesionaliai ar neteisingai gaminį instaliavus, nesilaikant gaminio naudojimo instrukcijų, naudojant gaminį ne pagal įstatymų numatytus standartus ar įprastinius tokio tipo gaminijų naudojimo procesus, naudojant gaminį kitai paskirčiai nei numatyta. ■ Gedimams, atsiradusiems dėl netinkamos ar nepakankamos gaminio priežiūros. ■ Gedimams, atsiradusiems dėl purvo, nenugalimos jėgos aplinkybių (stichinių nelaimių, gaisro, potvynio, . . .). ■ Gedimams, atsiradusiems dėl prastos kokybės signalo, elektromagnetinio lauko trikdžių ir kt. ■ Radius mechaninių pažeidimų (pvz. sulaužyti mygtukai, kritimo požymiai. . .). ■ Gedimams, atsiradusiems naudojant gaminį su netinkamomis laikmenomis, jungiant prie netinkamų tinklų, dedant į gaminį netinkamus maitinimo šaltinius (baterijas) ar dėl bet kokių kitų netinkamų naudojimo sąlygų (pvz. aukštos temperatūros, didelės drėgmės, žemės drebbėjimų. . .). ■ Nustačius, kad gaminys taisytas, modifikuotas ar ardytas neįgaliotų tai daryti asmenų. ■ Jei galutinis naudotojas neturi visų reikalingų dokumentų, įrodančių jo teisę į garantinį remontą (pvz. dokumento, kur būtų nurodytas gaminio įsigijimo laikas ir vieta). ■ Jei data pateiktuose dokumentuose skiriasi nuo datos ant gaminio.

Warunki gwarancji

Produkt objęty jest 24 – miesięczną gwarancją, począwszy od daty zakupu przez klienta. Gwarancja jest ograniczona tylko do przedstawionych dalej warunków. Gwarancja obejmuje tylko produkty zakupione w Polsce i jest ważna tylko na terytorium Rzeczpospolitej Polskiej. Gwarancja obejmuje tylko produkty funkcjonujące w warunkach gospodarstwa domowego (nie dotyczy produktów oznaczonych jako „Professional”). Zgłoszenia gwarancyjne można dokonać w autoryzowanej sieci serwisowej lub w sklepie, gdzie produkt został nabyty. Użytkownik jest zobowiązany zgłosić usterkę niezwłocznie po jej wykryciu, a najpóźniej w ostatnim dniu obowiązywania okresu gwarancyjnego. Użytkownik jest zobowiązany do przedstawienia i udokumentowania usterki. Tylko kompletne i czyste produkty (zgodnie ze standardami higienicznymi) będą przyjmowane do naprawy. Usterki będą usuwane przez autoryzowany punkt serwisowy w możliwie krótkim terminie, nieprzekraczającym 14 dni roboczych. Okres gwarancji przedłuża się o czas pobytu sprzętu w serwisie. Klient może ubiegać się o wymianę sprzętu na wolny od wad, jeżeli punkt serwisowy stwierdzi na piśmie, że usunięcie wady jest niemożliwe. Aby produkt mógł być przyjęty przez serwis, użytkownik jest zobowiązany dostarczyć oryginały: dowodu zakupu (paragon lub faktura), podbitej i wypełnionej karty gwarancyjnej, certyfikatu instalacji (niektóre produkty).

Gwarancja zostaje unieważniona, jeśli:

■ usterka była widoczna w chwili zakupu, ■ usterka wynika ze zwykłego użytkowania i zużycia, ■ produkt został uszkodzony z powodu złej instalacji, niezastosowania się do instrukcji obsługi lub użytkownika niezgodnego z przeznaczeniem, ■ produkt został uszkodzony z powodu złej konserwacji lub jej braku, ■ produkt został uszkodzony z powodu zanieczyszczenia, wypadku lub okoliczności o charakterze sił wyższych (powódź, pożar, wojny, zamieszki itp.) ■ produkt wykazuje złe działanie z powodu słabego sygnału, zakłóceń elektromagnetycznych itp., ■ produkt został uszkodzony mechanicznie (np. wylamany przycisk, upadek, itp.), ■ produkt został uszkodzony z powodu użycia niewłaściwych materiałów eksploatacyjnych, nośników, akcesoriów, baterii, akumulatorów itp. lub z powodu użytkowania w złych warunkach (temperatura, wilgotność, wstrząsy itp.), ■ produkt był naprawiany lub modyfikowany przez nieautoryzowany personel, ■ użytkownik nie jest w stanie udowodnić zakupu (nieczytelny paragon lub faktura), ■ dane na przedstawionych dokumentach są inne niż na urzędzeniu, ■ produkt nie może być zidentyfikowany ze względu na uszkodzenie numeru seryjnego lub plomby gwarancyjnej.

Uab „Senuka Prekybos
Centras“ Garantinis Servisas
Jonavos G. 62, Lt-44192,
Kaunas, Lithuania
Tel.: +370 37 212 146
Tex.: +370 37 212 165
garrem@senukai.lt
www.senukai.lt

Fast Poland, Sp. z o.o. Ul.
Kwietniowa 36
05-090 Wypędy
Poland
Tel.: +48 697 690 228
Mail: serwis@fastpoland.pl
www.fastpoland.pl



 **FIELDMANN**[®]
Home & Garden Performance